



**A1** FLUE  
SYSTEMS

Product catalogue

# Single-Skin Deltavent

# Single-Skin Deltavent

A multi-purpose lightweight, prefabricated Stainless Steel duct system designed to convey all associated products of combustion from a wide range of combustion and process appliances. Single-Skin Deltavent benefits from the ability to withstand continuous exhaust gas temperatures of up to 760°C and has been designated as (H1) for pressure resistance in accordance with BS EN 1856-1-2.

## The Single-Skin Deltavent Systems are designed for use where;

- A four hour fire rating is specified
- A positive pressure, relatively high temperature exhaust duct system is specified
- A watertight flue system is specified

## Application

- Condensing Boilers
- Smoke Extract
- C.H.P Systems
- Fan Assisted Flue System
- Kitchen Extract
- Flue Dilution

## Quality Assurance;

The complete range of components are manufactured, tested and where required installed within scope of stringent quality controlled conditions in accordance with EN ISO 9001:2015 and BS EN 1856-1/2:2009. When requested, A1 Flue Systems shall submit copies of type test reports relating to product performance in addition to the "Certificate of Registration" administered by the British Standards Institute.

## Fire Rating;

The Single-Skin Deltavent system has been successfully assessed by the Loss Prevention Council for Fire Resistance. A fire rating of 4 hours can be achieved in accordance with stability and integrity criteria of BS 476: part 20. If required, A1 Flue Systems shall submit all test reports in support.

## Construction;

Single-Skin Deltavent sections/fittings are fabricated in a variety of diameters and lengths with a continuously welded vertical seam. The (coupler) characteristics consist of male and female connection sockets complete with a 10mm 90° right angled flange formed at either end of all components.

Single-Skin Deltavent joints shall be secured by clamping an externally fitted V-Band over the mating flanges of the adjoining components. Sealant available from A1 Flue Systems, should be applied to the inside profile of the V-Band and to both flange faces before installation.

### Construction diagrams

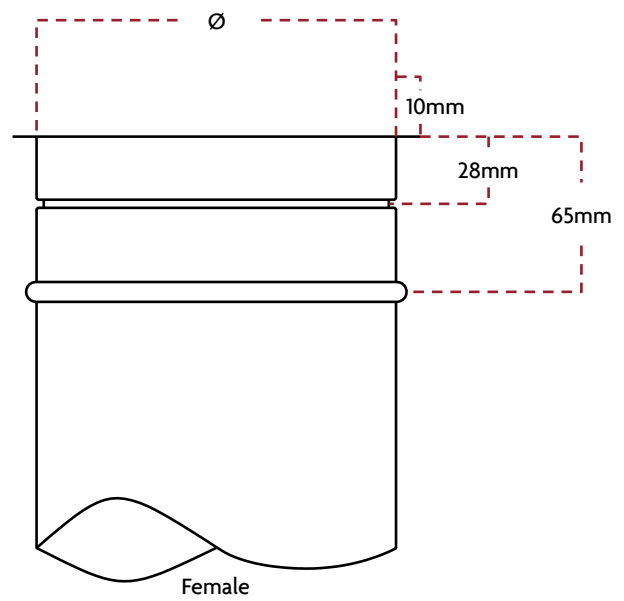
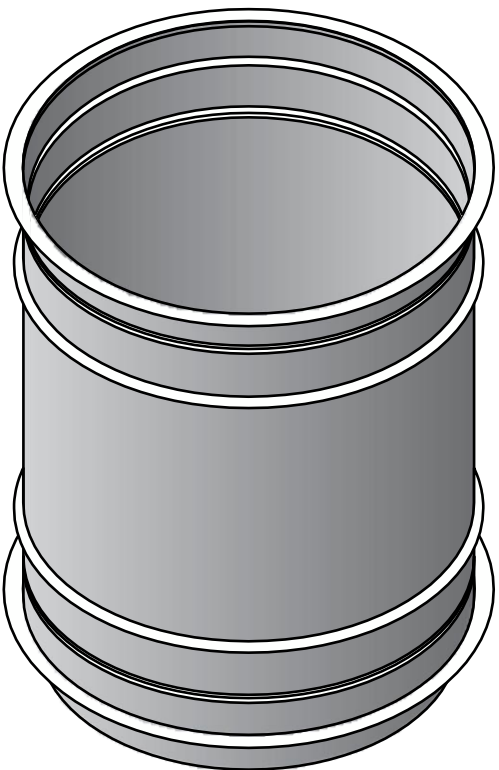
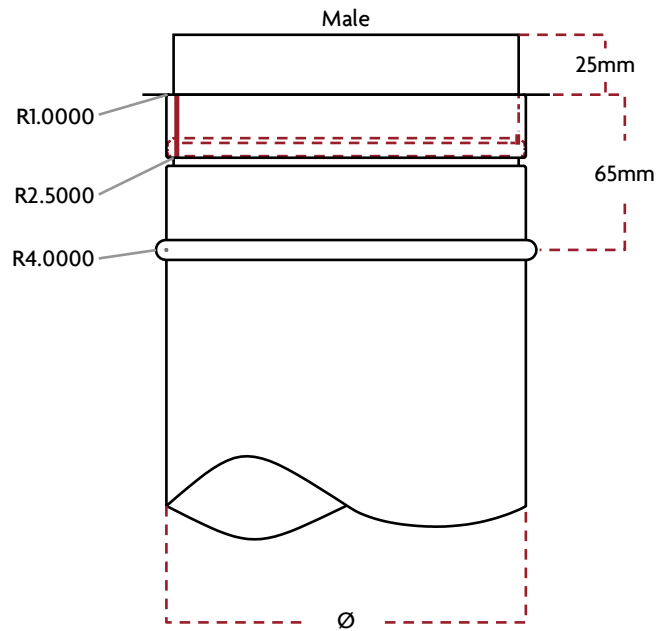
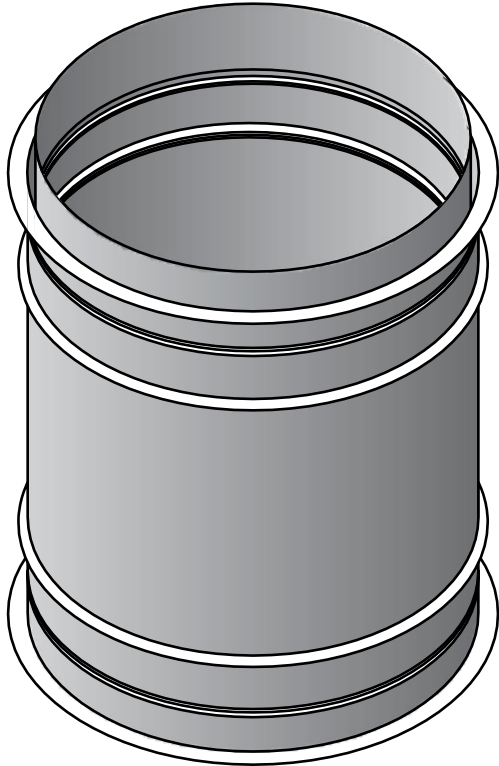

# Single-Skin Deltavent

## Penetrations;

A 50mm clearance between the external case of a chimney as it penetrates through a combustible/non-combustible structure must always be maintained using either a Fire Stop Kit or a Fire Stop support plate. Flue length selection must be that the coupler joints shall project at least 150mm below a ceiling or roof before a connection is made and no connection joint shall occur within the floor or roof assembly.

## Cleaning;

Conventional flue systems, once installed, require little or no maintenance. However, it is advisable to annually remove all clean out doors (if fitted) and check that the flue is unobstructed and there are no foreign bodies present.

## Caution;

Product handling, transporting and assembling should be undertaken with extreme care as all components consist of sharp coupler connections. Wearing protective gloves and other associated safety equipment is highly recommended to avoid injury from any exposed edges.

## Storage;

Flue components stored on site must be in a vertical orientation on a flat surface which will not damage the male connection spigot or coupler jointing detail. The components must also be kept in a dry environment located away from any on-going construction work, emergency exits or high active public areas.

## Material Specification;

150Ø - 1200Ø Sections, Fittings and Elbows shall be manufactured using the following materials;

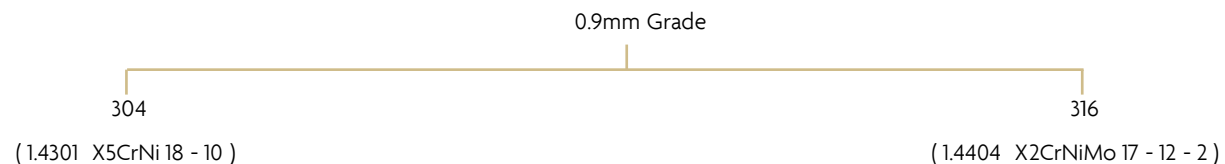

Alternative materials for 150Ø - 600Ø excluding Tee pieces.

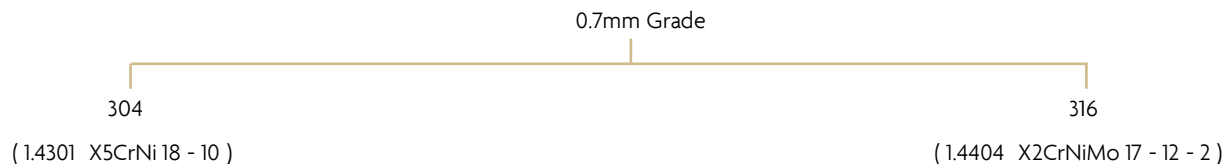

## Performance Designations;

The relevant technical performance classifications and designations for the Single-Skin Deltavent are ;

Standard	Product Designation					
BSEN 1856-1	T600	H1	D	Vml	20070	G(50)
				V2	50070	
				Vml	20090	
				V2	50090	
BSEN 1856-2	T200	H1	W	Vml	20070	G(50)
				V2	50070	
				Vml	20090	
				V2	50090	
	Temperature Class	Pressure Class	Condense Resistance	Corrosion Class	Material Specification Liner Grade & Thickness	Soot Fire Resistance

## The CE Designation Scheme

The compliance of a chimney system product to the relevant technical performance characteristics according to the designation scheme is described by the following example.

Product Description	Product Designation						
System Chimney Product	EN 1856-1	T450	H1	D	V1	L20091	G(50)
Metal Flue Lines	EN 1856-2	T160	P1	W	V1	L20056	O(50)
Connecting Flue Pipe	EN 1856-2	T200	P1	W	V2	L50056	G(50)
	Standard Number	Temperature Level °C	Pressure Level; N,P,H	Condensate Resistance	Corrosion Resistance	Flue Liner Specification	Soot Fire Resistance

## Product Description- Standard Number:

**EN 1856-1:** The standard for system chimney products - requirements for metal chimneys.

Comprising of a series of essential harmonised European Standards and elements for both single and multi-wall chimney products with rigid metallic liners.

**EN 1856-2:** Requirements for metal chimneys- part 2: Metal flue liners and connecting flue pipes

Relates to the essential harmonised European Standards and elements of all products used to convey the products of combustion from appliances to the outside atmosphere.

# Single-Skin Deltavent

## Temperature level:

Maximum continuous operating temperature (100-700°C). Example:

T160 (°C): suitable for Gas.

T200 (°C): suitable for Gas and Oil.

T450 (°C): suitable for Solid Fuel (multifuel).

## Pressure Level:

N: Negative pressure - natural draft.

(Fireplaces-stoves, atmospheric boilers - type B gas appliances).

P: Positive pressure - forced draft.

(Fan assisted boilers, type C gas appliances).

H: High pressure - industrial installations.

(Diesel generators)

Pressure Type	Test Pressure (Pa)	Leakage rate / Flue surface area (l/sec.m <sup>2</sup> )
N1	40	<2.0
P1	200	<0.006
P2	200	<0.120
H1	200 and 5000	<0.006
H2	200 and 5000	<0.120
	Standard Number	

## Condensate resistance:

W: Designates ability to contain condensate within the flue. (e.g. High efficiency condensing boilers).

D: Designates ability to operate under dry conditions only, usually meaning a flue gas temperature high enough to avoid condensate formation.

## Corrosion resistance:

Durability of the flue liner against corrosion. This is fuel dependent having the following classes based on three available types of testing.

V1: Tested and approved as resistant to attack from gas combustion products.

V2: Tested and approved as resistant to attack from light oil and natural wood combustion products (sulphur content < 0.2%). V3: Tested and approved as resistant to attack from heavy oil, solid fuels and peat combustion products (sulphur content > 0.2%).

Vm: Not tested but rating declared by the manufacturer.

#### **Flue Liner material specification:**

The material specification of the flue liner is formed by the letter (L) followed by five digits. The first two digits represent the material type according to Table 4 within BS-EN 1856-1. The last three digits represent the material thickness in multiples of the unit 0.01 mm.

#### **Example:**

L40045 represents a liner made of 1.4401 (316) stainless steel with a thickness of 0.45 mm.

#### **Soot fire resistance:**

**G:** Yes, the product has been tested at 1000°C for 30 minutes and has remained intact while the temperature of combustible material at the designated distance does not exceed 100°C at an ambient temperature 20°C.

**O:** No, all products with classification O mean the product is not rated as soot fire resistant. This is usually the case with low temperature applications such as condensing gas boilers, where seals are used, which would not withstand a soot fire.

#### **Distance to combustible material:**

Defined in soot fire resistance above. Distance between the outside surfaces of the chimney and adjacent combustible material, expressed in (mm).

#### **Example:**

O30 = not soot fire resistant with minimum installation distance of 30mm from adjacent combustible material.



# Single-Skin Deltavent

## Product Technical Information

According to BS EN 1856-1 Par. 7 and Annex ZA.1

Essential Characteristics: Requirements according to BS EN 1856-1	Levels and/or classes: Informative data	Document	Additional Information
Internal diameters Par. 4 .b	Available in diameters of 150mm-1200mm	Manufacturer's declared	Product catalogue Factory Production Control (Continuous Surveillance)
Liner Material Par. 4 .a and Par. 6.7.2	304 (1.4301 X5CrNi 18-10) 0.7mm + 0.9mm 316 (1.4404 X2CrNiMo 17-12-2)0.7mm + 0.9mm	Manufacturer's declared	Product catalogue Factory Production Control (Continuous Surveillance)
Wind Load Resistance Par. 7.2 .d and Par. 6.2.3.2	Limitations of height location of exposed section of the chimney shall be 2.5 meters Maximum distance between lateral supports shall be 3.0 meters. Complied with the applied load of 312Kg on 200 Ø sections and fittings.	Manufacturer's declared Test report 19404/1/2/3/4	Annex A + Typical Installation
<b>Compressive strength Par.7.2.e and Par.6.2.1</b>			
Chimney sections and fittings Par.6.2.1.1 Chimney support Par.6.2.1.2	Chimney sections, fittings and Supports shall withstand an intensity of load of at least 3 x the declared design load, as per EN 1859 ( Designated by the distance between supports)	Test report 19404/1/3/4 + Test report AL3484	Annex A + Typical Installation
Tensile strength Par.6.2.2	Chimney shall withstand a load of at least 1.5 x manufacturer's declared, as per EH 1859	Test report 19404/1/3/4	
Lateral strength Par.6.2.3	Non-vertical installation. Maximum distance unsupported at 45° of 1.5 meters Vertical installation. Maximum spacing of lateral supports of 3.0 meters	Manufacturer's declared	Annex A + Typical Installation
Distance to combustibles, temperature related Par.7.2.f and Par.6.6.1	T600: 50mm T200:50mm	Test report 19404/1/3/4	
Flow resistance Par.7.2.g and Par.6.6.7	Mean value of roughness as per EN 13384-1:2002 Table B.4. of rigid liners, rigid connecting flue pipes and fittings shall be 0.001m.	Manufacturer's declared Test report 19404/1/3/4	
Thermal resistance Par.7.2.h and Par.6.6.3	Single-skin Deltavent pressure resistant flue liner is not insulated		
Thermal performance Par.6.6.1	Performance tests for designations	Test report 19404/1/3/4	Appendix A tests 4, 5, 6, 9, 10, and 11
Accidental human contact Par.6.6.2	Provide protective shield and/or place warning signs in access areas	Test report 19404/1/3/4	Appendix A tests 1, 2, 3, and 8
Gas tightness Par.6.5 and Table 1	The leakage rate for gas tightness 0.00064 l/s/m <sup>2</sup> . Designation (HI)	Test report 19404/1/3/4	Factory Production Control (Continuous Surveillance)
Sootfire resistance Par.6.4	G(50):Yes Applies O(50):No	Test report 19404/1/3/4	
Water vapour diffusion resistance Par.6.6.4	D(Dry) T450 +T600 W(Wet)T200	Test report 19404/1/3/4	
Durability against corrosion Par.6.7	Stainless steel 304 (1.4301) or 316 (1.4404) 0.7mm and 0.9mm grades	Manufacturer's declared	Product catalogue

The tables below provide the weight of essential Single-Skin Deltavent components and the maximum Design Load (Kg)/number of metre lengths that can be applied to standard support assemblies.

**Weight per metre (Kg):**

Diameter	150	200	250	300	350	400	450	500	550
	3.64	4.85	6.06	7.27	8.49	9.7	10.91	12.12	13.33
Diameter	600	650	700	750	800	850	900	950	1000
	14.55	15.76	16.97	18.18	19.38	20.61	21.82	23.03	24.24
Diameter	1050	1100	1150	1200					
	25.46	26.67	27.88	29.09					

**Thrust Support Plates (Kg):**

Diameter	150	200	250	300	350	400	450	500	550
	3.07	3.78	4.94	5.61	6.67	7.62	8.65	9.68	11.06
Diameter	600	650	700	750	800	850	900	950	1000
	12.08	13	14.4	14.72	16.05	17.3	18.3	19.68	20.88
Diameter	1050	1100	1150	1200					

**B-Types (Kg):**

Diameter	150	200	250	300	350	400	450	500	550
	0.5	0.6	0.71	0.87	0.97	1.1	1.2	1.32	4.76
Diameter	600	650	700	750	800	850	900	950	1000
	2	2.44	2.86	3.01	3.08	3.3	3.48	3.72	3.9
Diameter	1050	1100	1150	1200					

**Guide B-Types (Kg):**

Diameter	150	200	250	300	350	400	450	500	550
	1.64	2.04	2.45	2.85	3.24	3.66	4.06	4.4	4.82
Diameter	600	650	700	750	800	850	900	950	1000
	5.08	5.44	5.8	6.2	6.46	6.76	7.16	7.68	8.02
Diameter	1050	1100	1150	1200					

# Single-Skin Deltavent

## Annex A

Thrust Support Design Load (Kg) & Lengths accepted (m):

Design loads stated have been calculated in accordance with BS EN 1856-1 and BS EN 1859, therefore any information obtained shall only be used as a guide. Adequate fixing to a suitable structure must also be achieved on installation to obtain maximum load acceptance.

Diameter	150	200	250	300	350	400	450	500	550
Load	32.76	43.65	54.54	65.43	76.41	87.3	98.19	109.08	119.97
Lengths	9	9	9	9	9	9	9	9	9
Diameter	600	650	700	750	800	850	900	950	1000
Load	130.95	141.84	152.73	163.62	174.51	185.49	196.38	207.27	218.16
Lengths	9	9	9	9	9	9	9	9	9
Diameter	1050	1100	1150	1200					
Load	229.14	240.03	250.92	261.81					
Lengths	9	9	9	9					

Typical Installation:

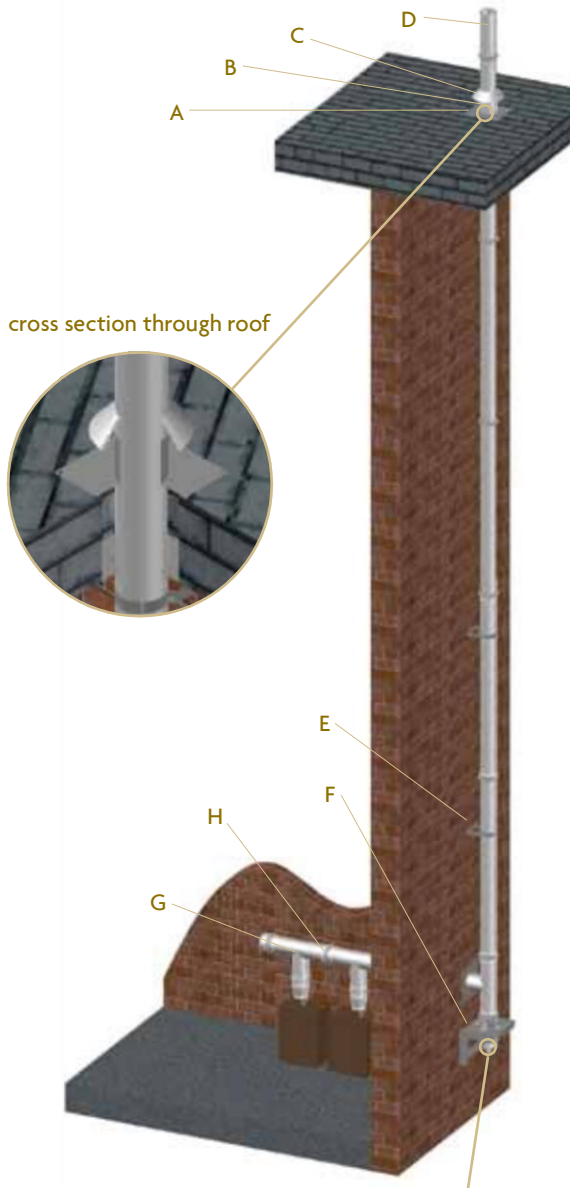

- A= Flat Flashing Plate
- B= Flashing Collar
- C= Storm Collar
- D= Top Stub Termination
- E= B Type Support Bracket
- F= Base Wall Support
- G= Cleanout/Inspection Door
- H= Standard 90° Tee
- I= Cleanout Door with drain point



Termination assembly

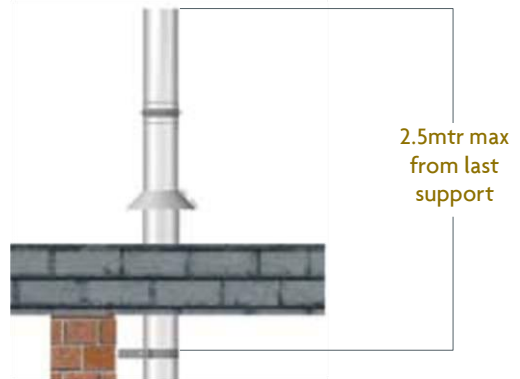

Support assembly

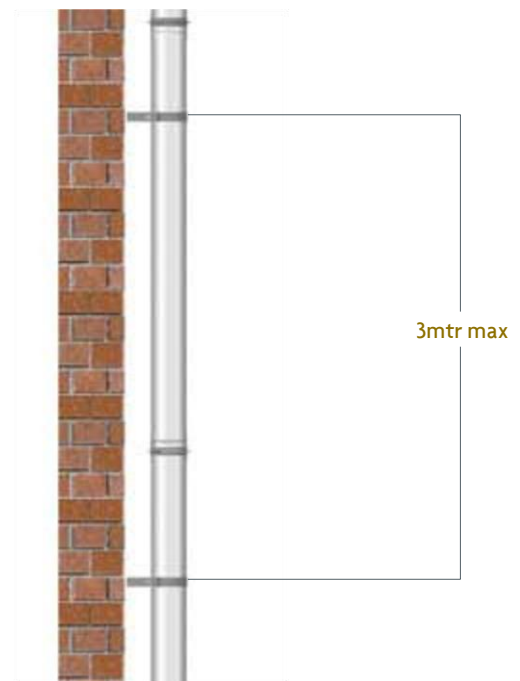

Offset assembly

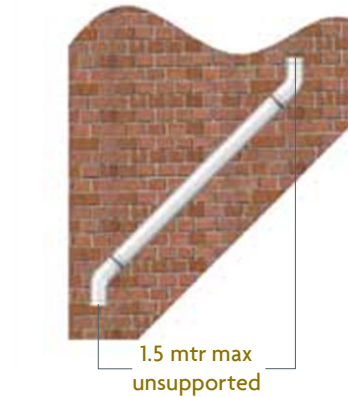

# Single-Skin Deltavent

## Product Marking:

According to BS EN 1856-1: 2009

## Chimney Identification Plate Example:

In accordance to BS EN 1856-1: 2009, chimney identification plates retaining information related to product specifications and designations are to be permanently secured to a chimney system and/or in close proximity to it, in an un-obstructive but visible location. Suitable fixing positions would be either to/or near any Clean Out Doors, Draught Stabilisers, Manual Dampers or boiler connection components. It is also extremely important that this plate is not removed or defaced at any point.

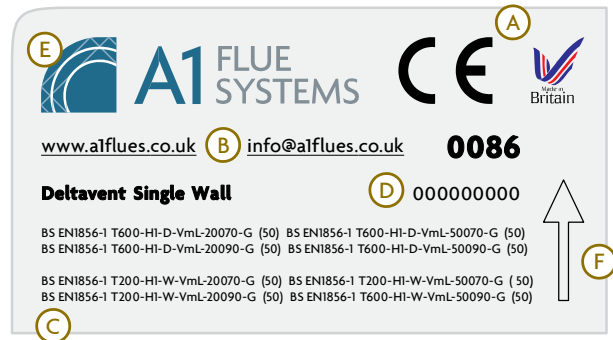

A = CE Conformity Mark & Identification Number

B = Manufacturer's Contact Details

C = Product Designators

D = Factory Production Control Certificate Number

E = Manufacturer's Name & Trademark

F = Gas Flow Direction

## Straight lengths.

Straight lengths are available as standard in 300mm, 450mm, 600mm, 750mm, 1000mm and 1200mm lengths. These are all the installed effective lengths.

We also manufacture any fixed length between the standard lengths to your requirements.

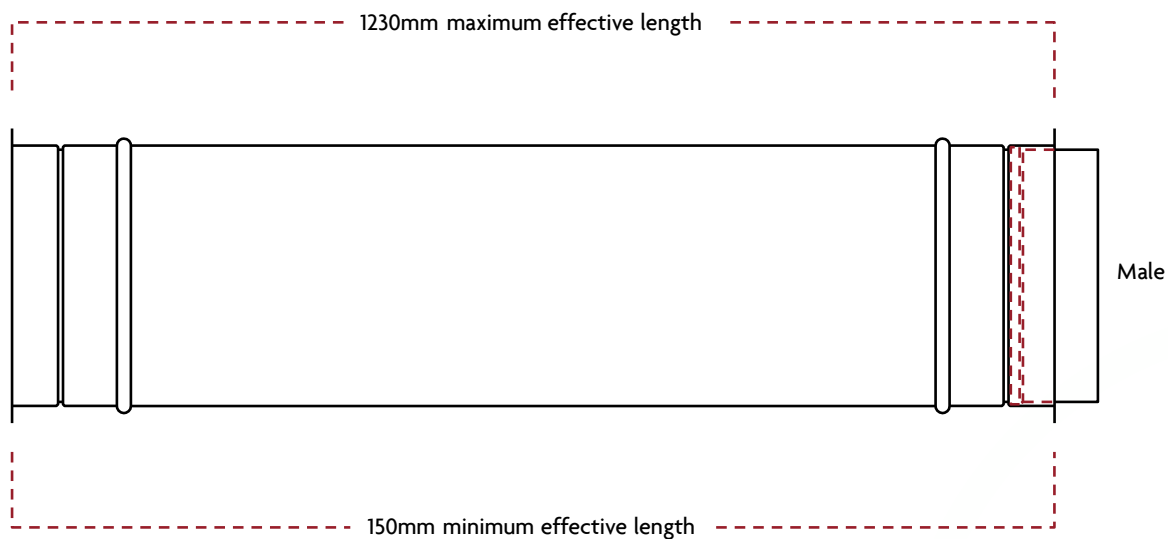

### Prior to installation

Before the installation of a Single-Skin Deltavent flue you must be aware, in a vertical application it is essential that the components are installed with male spigot down against the flow of gases. This will allow condensates, to remain within the flue.

The Single-Skin Deltavent system also uses two types of sealant. For low temperature systems, 150° and below, a high durability/low temp silicone sealant is used and for systems with temperatures in excess of 150-550°, high temperature ceramic exhaust paste is used. The correct sealant must be used to seal the two connection flanges. Sealant is chosen according to the flue type and gas temperature.

Sealants for all applications are available and are supplied with the product.

### Installation

Ensure all components that require sealant are clean from any dirt, grease and other contaminants. Once the decontamination has been achieved, apply an adequate amount of sealant to the male flange connection (refer to illustration).

Using the locating spigot of the male as a guide, simply push/slot the two parts of Single-Skin Deltavent together (male spigot runs down).

The next step is to fit the V-Band supplied. This has been designed as a two-piece item for easy assembly and must also be free from any contaminants i.e., grease or oil. Sealant is then to be applied into the groove of the V-Band before fitting. Position both V-Band parts around the Single-Skin Deltavent with the 10mm connection flanges located within the groove. Tightly fasten both joints using the stainless steel nuts and bolts provided.

#### CAUTION:

It is extremely important for nothing to pierce the flue at any time of installation. Please note, during installation the weld should always be installed to at least 90° to the floor.

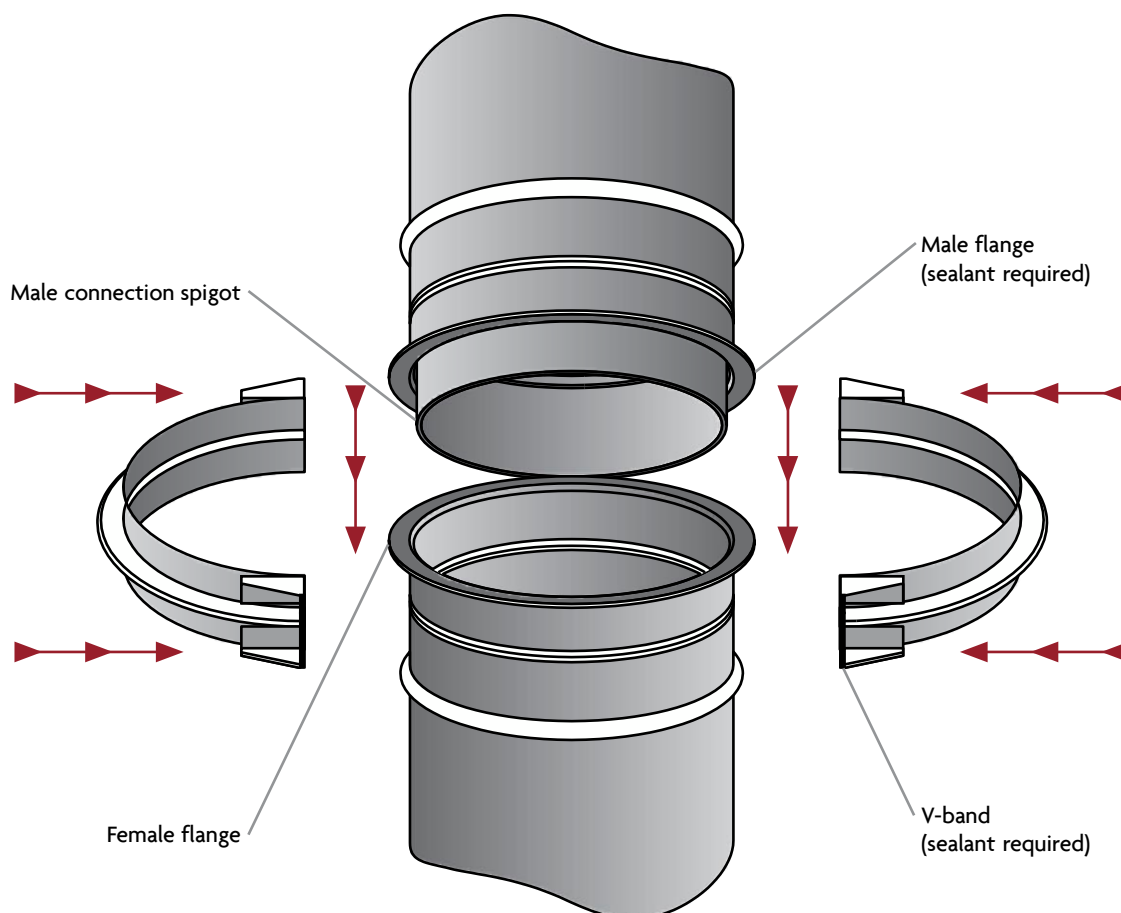

# Single-Skin Deltavent

## Single-Skin Deltavent Adjustable Lengths

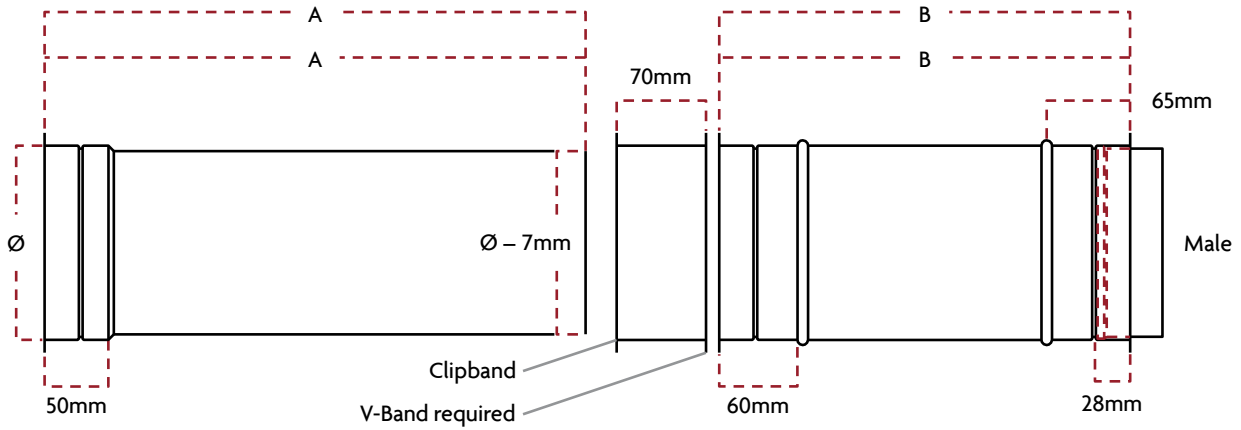

450-650 adjustable & expansion lengths; A = 410mm  
 600-950 adjustable & expansion lengths; A = 560mm

450-650 adjustable & expansion lengths; B = 300mm  
 600-950 adjustable & expansion lengths; B = 465mm

Single-Skin Deltavent Adjustable Lengths have been successfully designed to allow for greater flexibility when measuring or installing a chimney system.

This component is obtainable in 450mm-650mm and 600mm-950mm lengths (as standard) complete with a locking Clip band, V-Band and suitable Cover band if required. Non-standard Adjustable Lengths consisting of dimensions above those given can also be accommodated.

Once the Adjustable Length is in position and the length required has been achieved, it is then secured using both V-Band and Clip band. (refer to illustration)

**CAUTION:** Adjustable lengths DO NOT LOAD BEAR and should never be placed in a vertical rise unless sufficient support is in place.

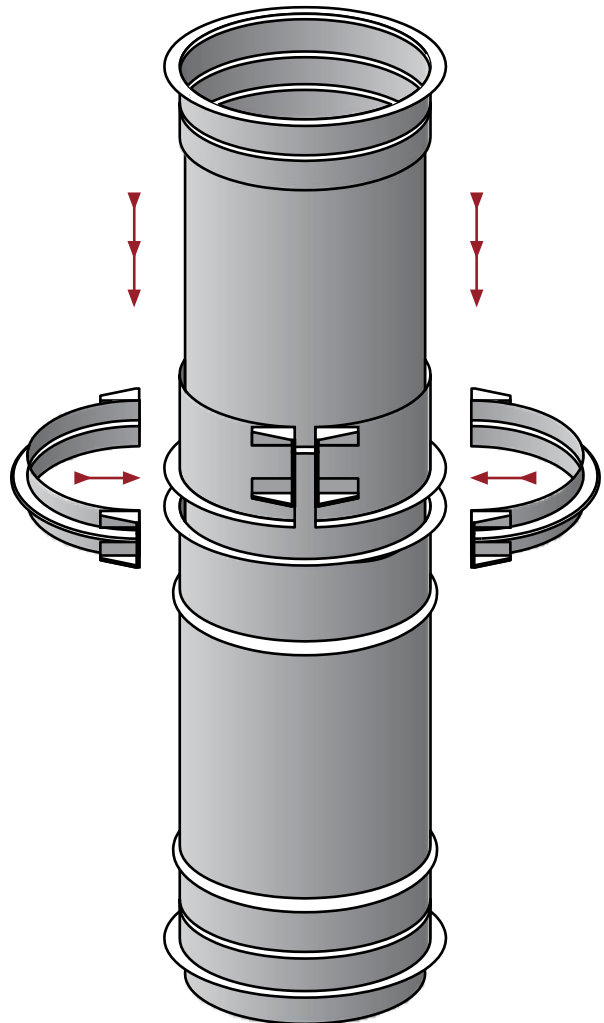

### Single-Skin Deltavent Expansion Bellows

The Expansion Bellow is designed to compensate for thermal and mechanical movement from within a chimney run whilst maintaining a high-pressure seal.

This item is frequently used with Diesel Engines and Gas Turbine Exhaust Systems and are available either lined or unlined.

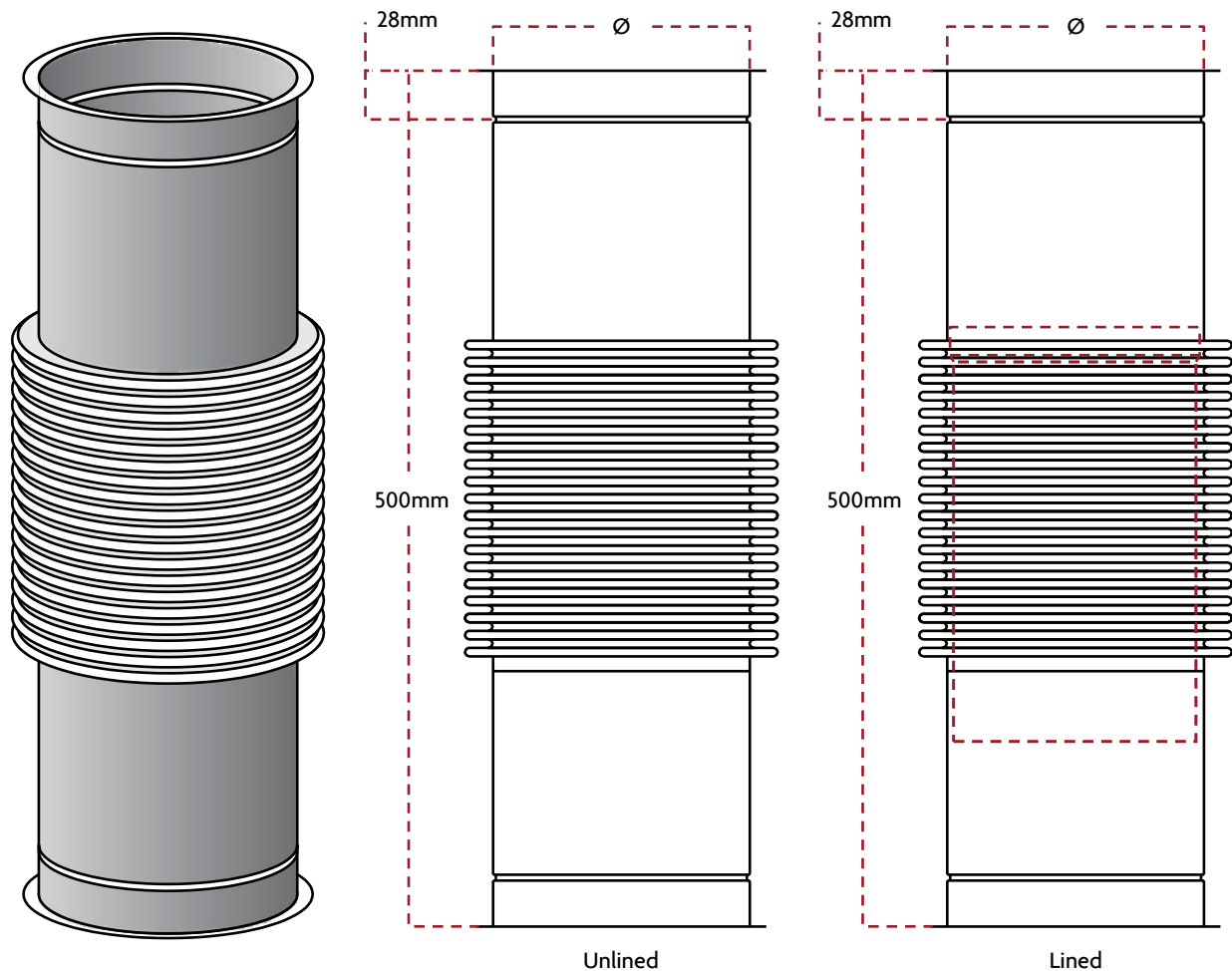

**NOTE:** Expansion Bellows for the Single-Skin Deltavent are to be concealed using a cover jacket, to protect against any external environmental issues and human intervention (Cover jacket provided separately)

Lined Bellows allow for better transition of flue gases to the atmosphere. However, this restricts the movement of the Bellow to linear expansion only.



# Single-Skin Deltavent

## Single-Skin Deltavent Tees

### 90° Tees

The 90° Tee is designed specifically to provide a change in chimney flue direction and to accommodate accessibility points for inspections/cleaning or moisture release drain points. This component is frequently used at the base of a vertically rising flue system and can also be assembled in multiples to create complete header configurations.

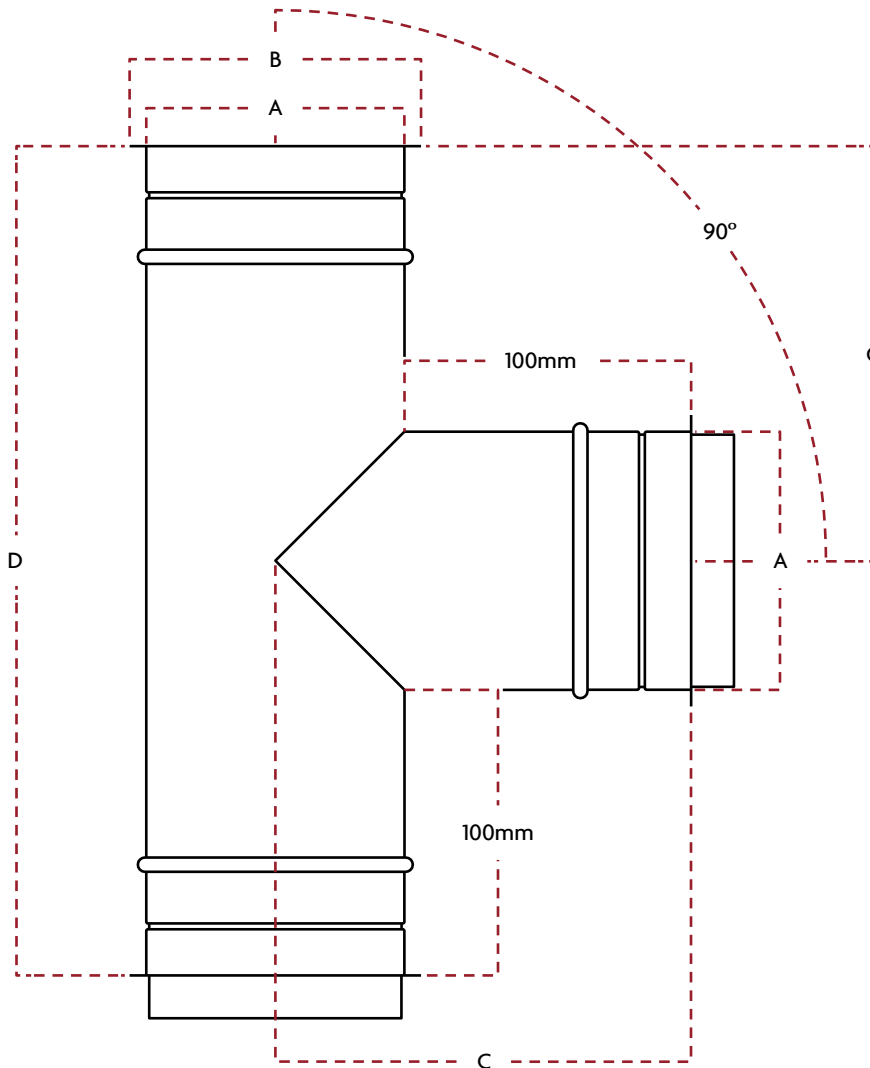

### Single-Skin Deltavent

ø A	100	125	150	175	200	225	250	300	350	400	450	500	550	600	650	700	750	800	850	900	950	1000
B	120		170	195	220	225	250	275	300	350	400	450	500	550	600	650	700	750	800	850	900	950
C	150		175	188	200	213	225	250	275	300	325	350	375	400	425	450	475	500	525	550	575	600
D	300		350	376	400	426	450	500	550	600	650	700	750	800	850	900	950	1000	1050	1100	1150	1200

All dimensions given above are standard minimum.

However, the possibility of manufacturing and supplying a non-standard tee with or without a reduced branch diameter and at dimensions above those given is also available.

### 135° Tees

The 135° Tee is also designed to provide a change in chimney flue direction but with the added advantage of a swept entry or exit to reduce resistance to the flow of the flue gases.

All dimensions given below are the standard minimum. However, non-standard tees with or without a reduced branch diameter and at any angle is available on request.

To calculate Tee body length;  $\varnothing / \cos \text{angle} + 200\text{mm}$

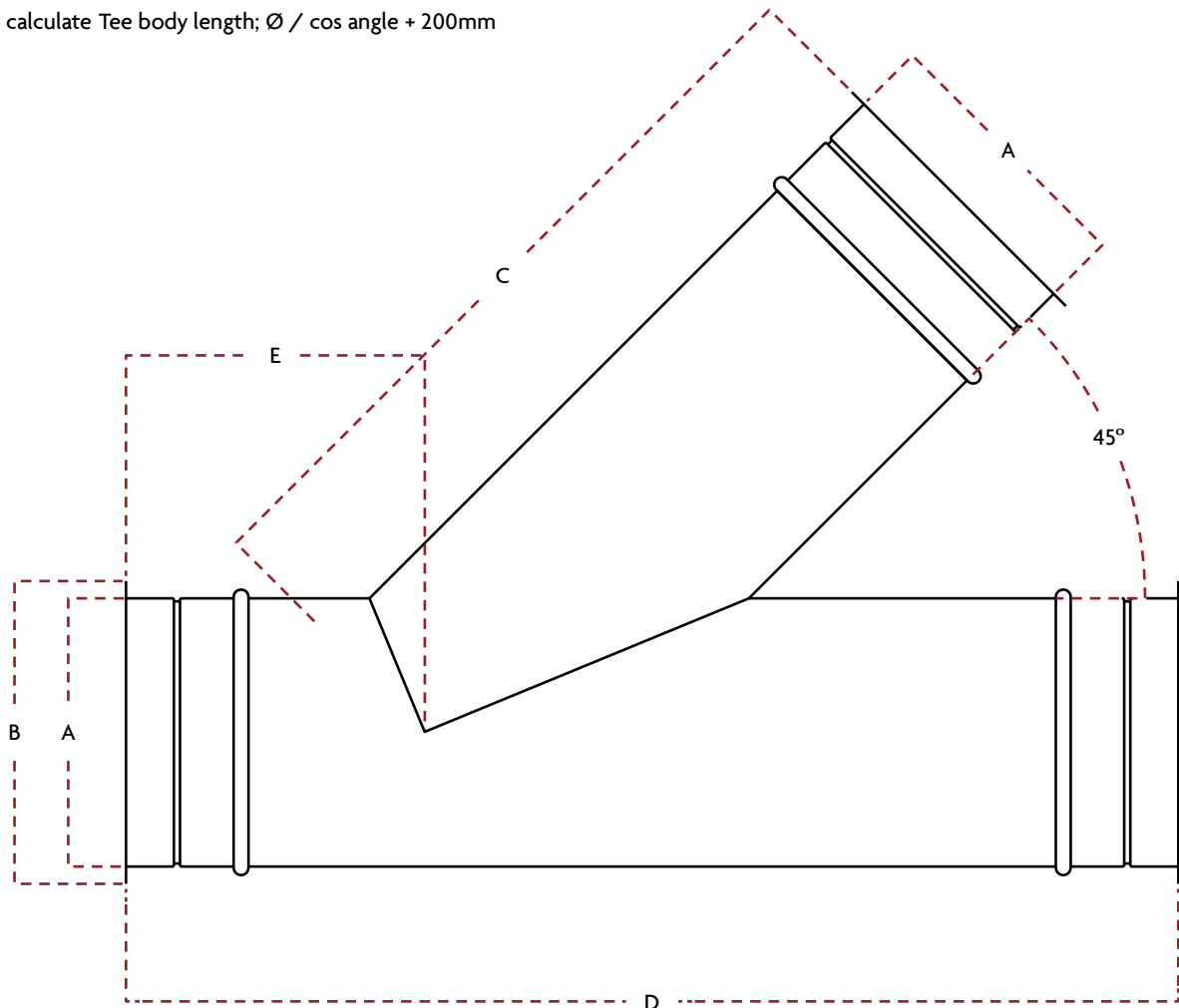

### Single-Skin Deltavent

$\varnothing$ A	100	125	150	175	200	225	250	300	350	400	450	500	550	600	650	700	750
B	120		170	195	220	245	270	320	370	420	470	520	570	620	670	720	770
C	221		281	311	341	371	401	462	522	582	643	703	763	824	884	944	1005
D	342		412	447	482	518	554	624	694	765	836	907	977	1048	1119	1189	1260
E	121		131	136	141	146	151	162	172	182	193	203	213	224	234	244	255

# Single-Skin Deltavent

## 90° Booted Tees

The 90° Booted Tee is also designed to provide a change in chimney flue direction but with the added advantage of a swept entry or exit to reduce resistance to the flow of flue gases.

The equal tee can be manufactured to dimensions below those given with or without a reduced branch diameter and at certain angles.

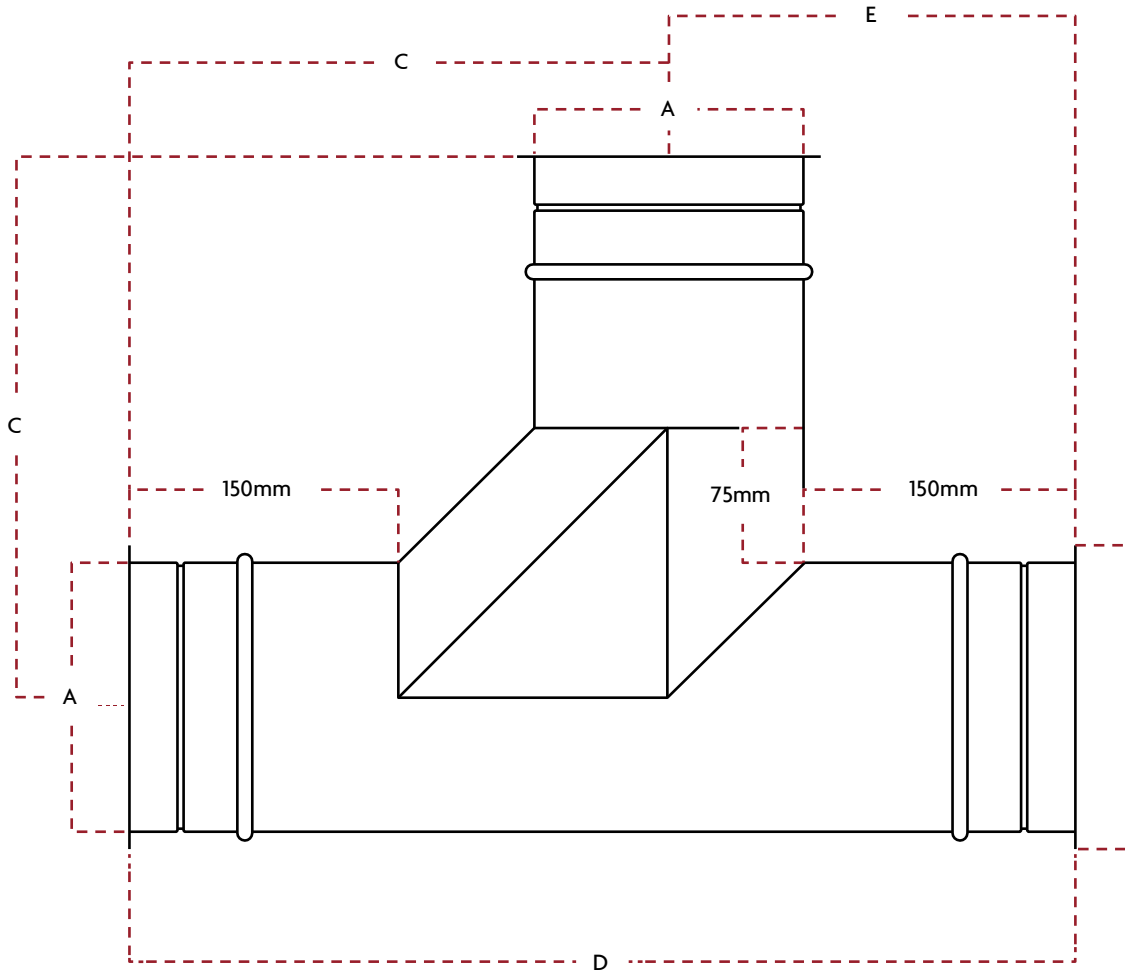

## Single-Skin Deltavent

∅ A	100	125	150	175	200	225	250	300	350	400	450	500	550	600	650	700	750	800	850
B	120		170	195	220	245	270	320	370	420	470	520	570	620	670	720	770	820	870
C	275	300	313	325	338	350	375	400	425	450	475	500	525	550	575	600	625	650	
D	475	525	551	575	601	625	675	725	775	825	875	925	975	1025	1075	1125	1175	1225	
E	200	225	238	250	263	275	300	325	350	375	400	425	450	475	500	525	550	575	

## Single-Skin Deltavent Elbows

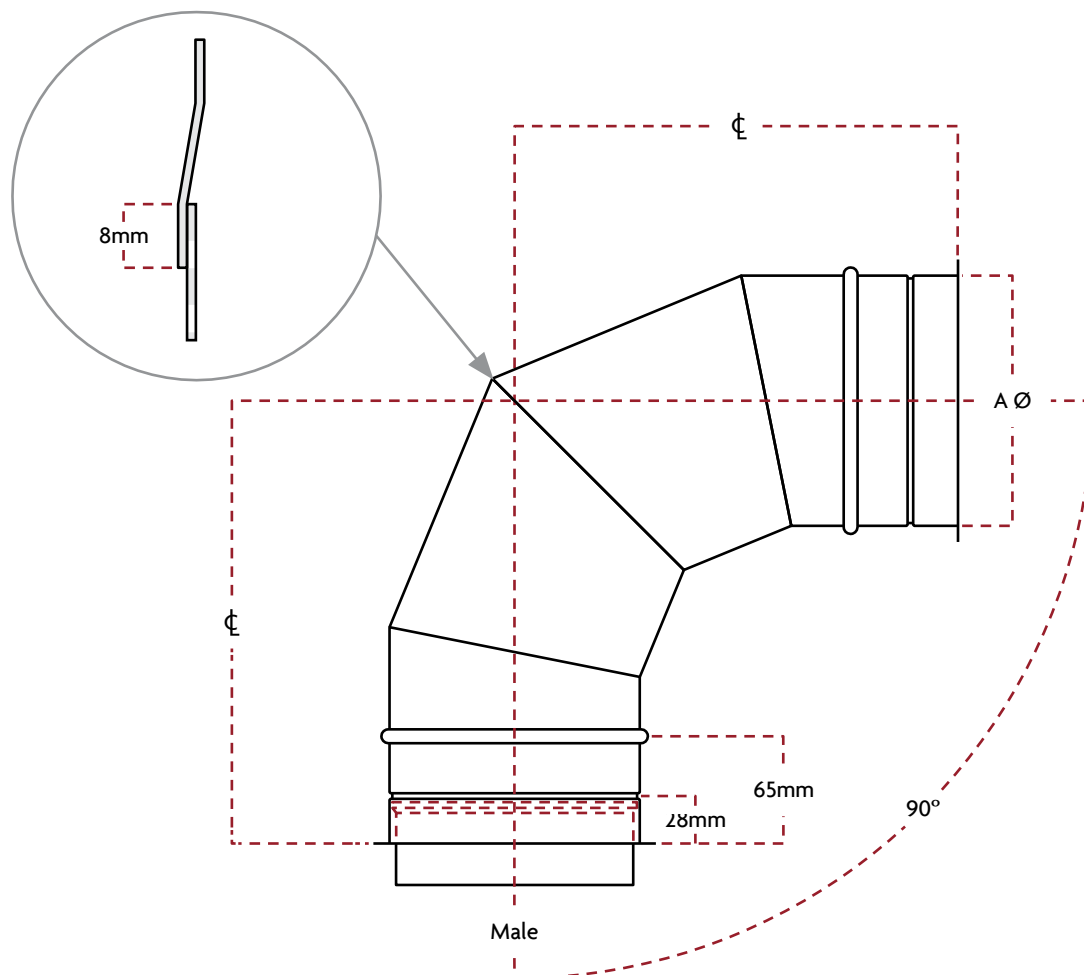

Single-Skin Deltavent Elbows are used when a change in direction is required within a chimney system. By adjoining and incorporating Elbows with various straight lengths and adjustable lengths, offsets can be tailor made to suit your requirements.

All information provided below are the standard minimum. However, the possibility of manufacturing and supplying Elbows with one or both centre lines extended and at any angle is available on request.

The entire range of Single-Skin Deltavent Elbows consist of fixed liner segments which are joined with an 8mm overlap joint, Resistance Welded together.

∅ A	100	125	150	175	200	225	250	300	350	400	450	475-750	775-1200
C	205		230	245	260	275	305	330	360	385	425	468-894	972-1187

**CAUTION: Single-Skin Deltavent Elbows DO NOT LOAD BEAR.**

Green = Made from 2 x Non-Standard 45 Degree Elbows

Blue = Made from 3 x Non-Standard 30 Degree Elbows

# Single-Skin Deltavent

CAUTION: Single-Skin Deltavent Elbows DO NOT LOAD BEAR.

Blue = Made from 2 x Non- Standard 30 Degree Elbows

Green = Made from 4 x Non-Standard 30 Degree Elbows

D & E = Refer to illustration.

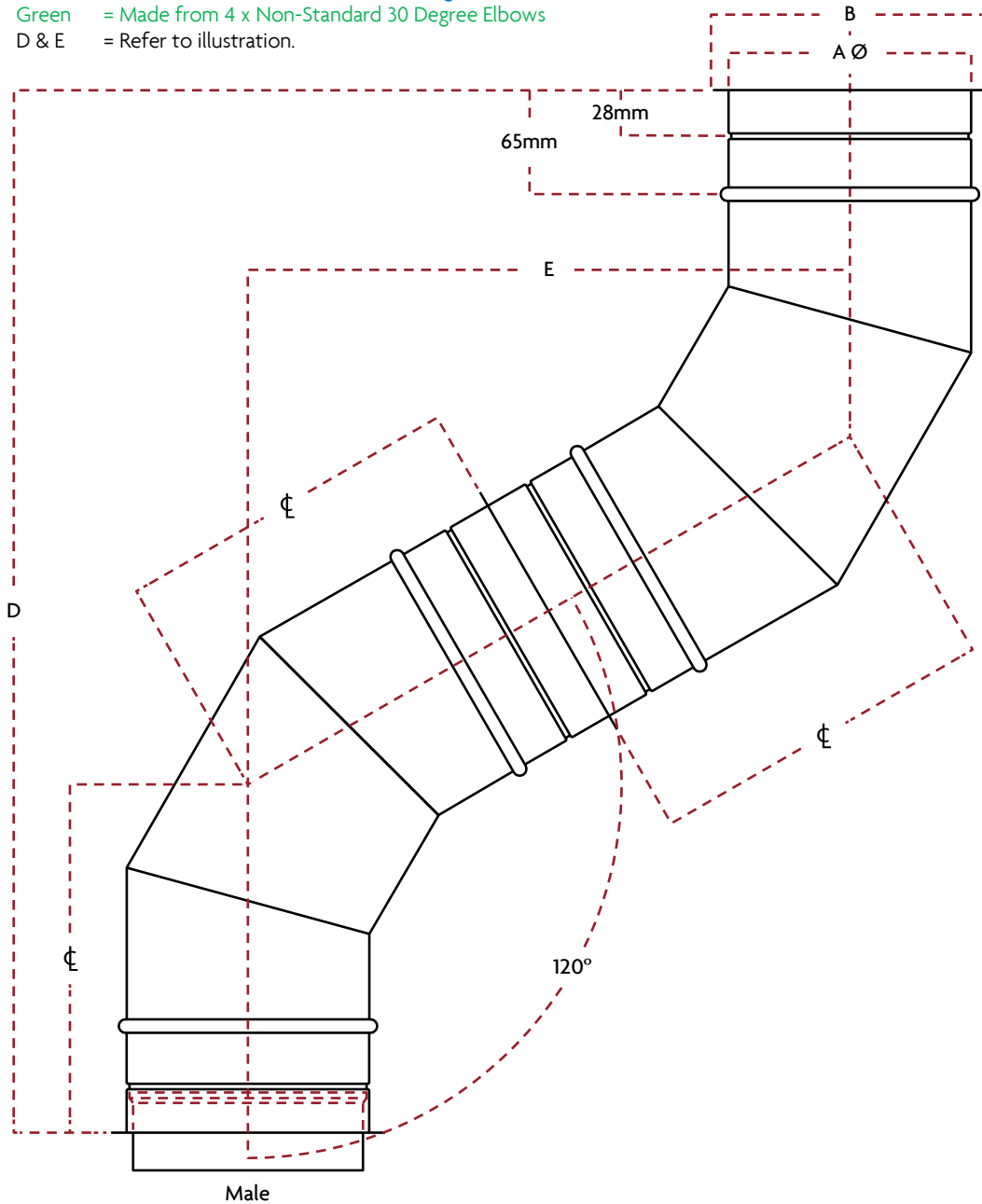

Single-Skin Deltavent 60° Elbow

∅ A	100	125	150	175	200	225	250	300	350	400	450	500	550	600	650	700	725-1200
B	120		170	195	220	245	270	320	370	420	470	520	570	620	670	720	745-1220
C	165		175	180	190	200	210	220	250	270	280	290	310	350	370	390	525-685
D	495		525	540	570	600	630	660	750	810	840	870	930	1050	1110	1170	1574-2056
E	286		303	312	329	346	364	381	433	468	485	502	537	606	641	675	909-1187

EXCELLENCE • PRIDE  
PASSION • PRECISION

Sytems House, Maun Way, Boughton Industrial Estate, New Ollerton, Nr. Newark, Nottinghamshire, NG22 9ZD  
Te: +44 (0)1623 860 578 Fax: +44 (0)1623 835 548 info@a1flues.co.uk www.a1flues.co.uk

**CAUTION: Single-Skin Deltavent Elbows DO NOT LOAD BEAR.**

Blue = Made from 2 x Non- Standard 22.5 Degree Elbows  
 Green = Made from 4 x Non-Standard 22.5 Degree Elbows  
 D & E = Refer to illustration.

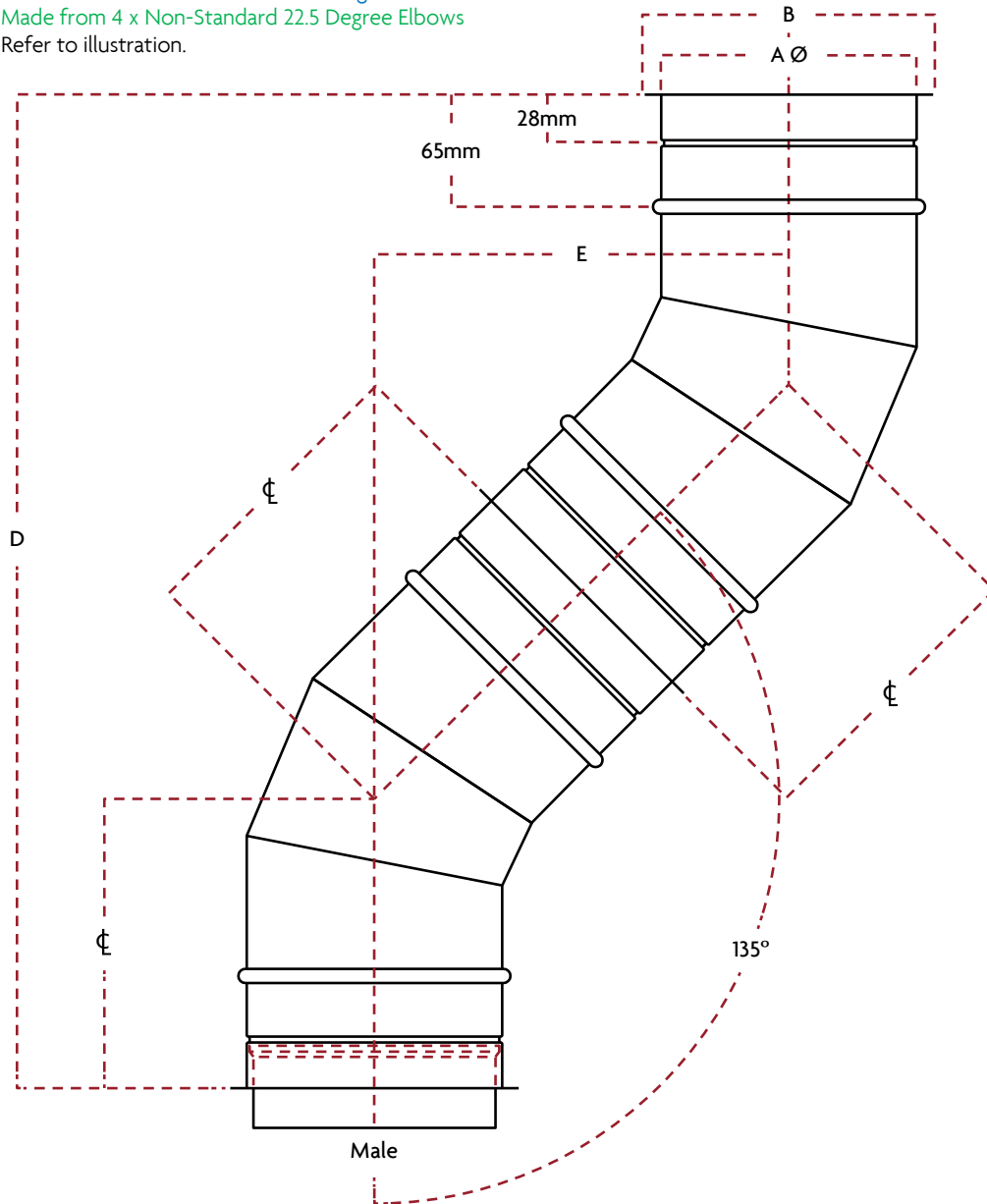

### Single-Skin Deltavent 45° Elbow

ø A	100	125	150	175	200	225	250	300	350	400	450	500	550	600	650	700	750	800	850	900	950	1000-1200
B	120		170	195	220	245	270	320	370	420	470	520	570	620	670	720	770	820	870	920	970	1050-1250
C	140		150	155	160	165	180	185	200	210	225	245	250	260	280	290	370	380	391	401	411	476-517
D	478		512	529	546	563	616	632	683	717	768	836	854	888	956	990	1263	1297	1335	1369	1403	1625-1764
E	198		212	219	226	233	256	262	283	297	318	346	354	368	396	410	523	537	553	567	581	673-731

# Single-Skin Deltavent

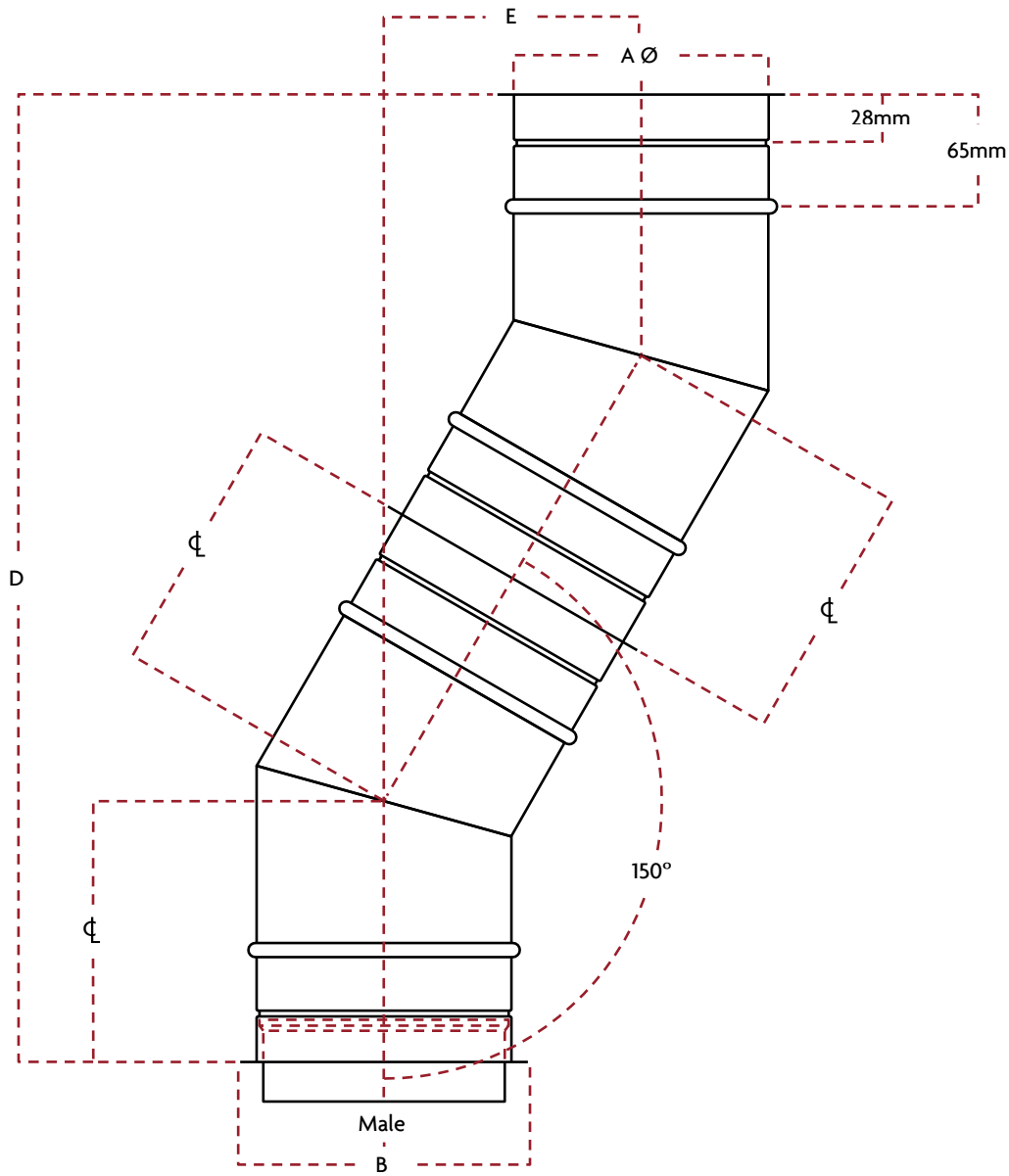

Single-Skin Deltavent 30° Elbow

ø A	100	125	150	175	200	225	250	300	350	400	450	500	550	600	650	700	750	800	850	900	950	1000	1050	1100	1150	1200
B	120		170	195	220	245	270	320	370	420	470	520	570	620	670	720	770	820	870	920	970	1020	1070	1120	1170	1220
C	125		132	135	140	143	152	158	165	172	178	185	190	210	220	230	257	264	270	277	284	291	297	304	311	318
D	467		493	504	522	534	567	590	616	642	664	690	709	784	821	858	959	985	1008	1034	1060	1088	1108	1135	1161	1187
E	125		132	135	140	143	152	158	165	172	178	185	190	210	220	230	257	264	270	277	284	291	297	304	311	318

EXCELLENCE • PRIDE  
PASSION • PRECISION

Sytems House, Maun Way, Boughton Industrial Estate, New Ollerton, Nr. Newark, Nottinghamshire, NG22 9ZD  
Te: +44 (0)1623 860 578 Fax: +44 (0)1623 835 548 info@a1flues.co.uk www.a1flues.co.uk

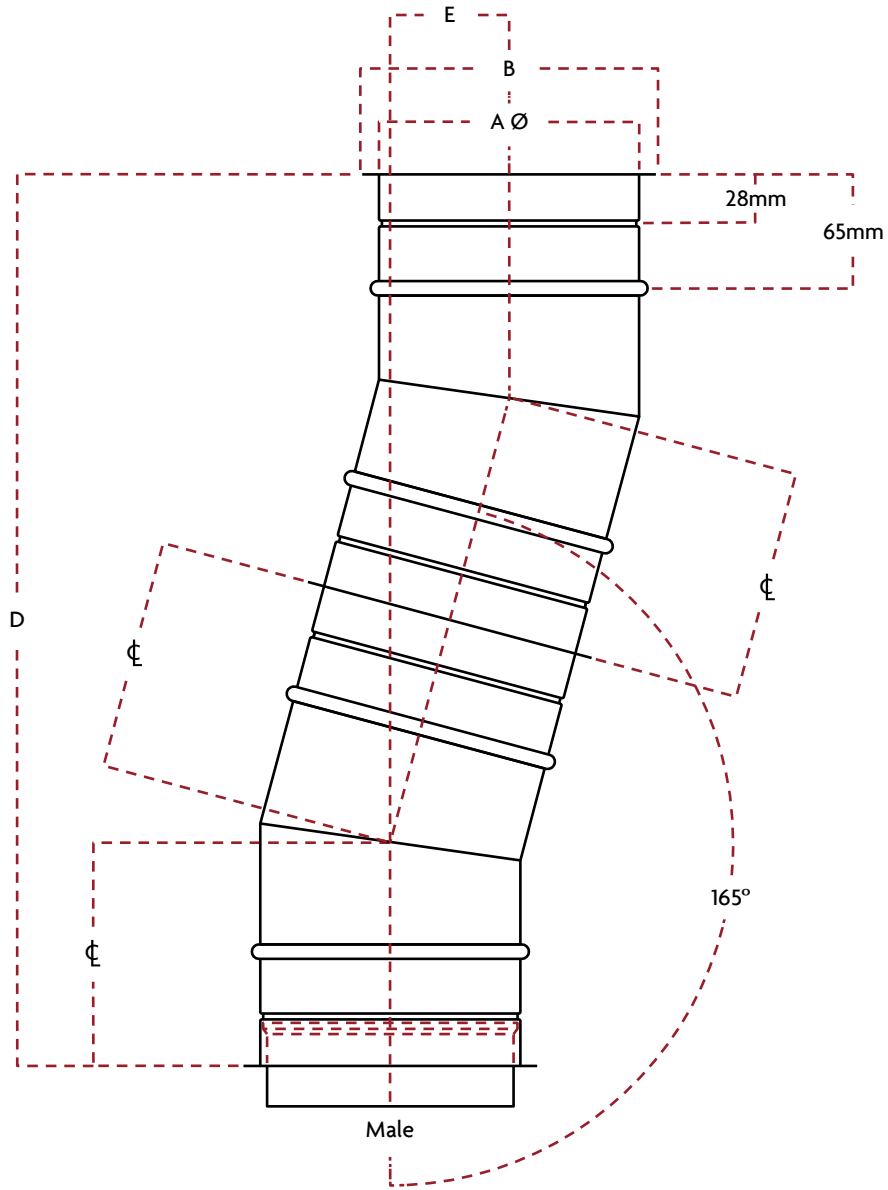

Single-Skin Deltavent 15° Elbow

ø A	100	125	150	175	200	225	250	300	350	400	450	500	550	600	650	700	750	800	850	900	950	1000	1050	1100	1150	1200
B	120		170	195	220	245	270	320	370	420	470	520	570	620	670	720	770	820	870	920	970	1020	1070	1120	1170	1220
C	115		119	120	122	124	127	134	137	141	144	147	151	164	173	175	203	206	209	213	216	219	222	226	230	234
D	452		469	471	479	487	500	526	539	554	568	578	593	645	682	690	798	811	821	837	850	860	873	889	904	920
E	60		62	62	63	64	66	69	71	73	75	76	78	85	90	91	105	107	108	110	112	113	115	117	119	121



# Single-Skin Deltavent

## Drain Lengths.

The purpose of a drain length is to relieve the flue system from any unwanted moisture (condensates). Introducing such items in the design is paramount for prolonging reliability of an appliance.

Drain lengths consist of a 1inch Stainless Steel B.S.P threaded socket which is fully welded onto the flue. Drains are obtainable on Single-Skin Deltavent standard lengths and can also be fitted to non-standard lengths above our minimum. (Refer to illustration)

## Vertical

Vertical Drain Lengths are manufactured and supplied complete with Drain Traps integrated within the liner.

This 'Trap' collects and diverts all moisture directly to and out of the drain.

## Horizontal

Horizontal Drain Lengths do not have the Internal Drain Trap fitted and should be incorporated, either at the end or in several positions within a run assembled with a 3-5° incline.

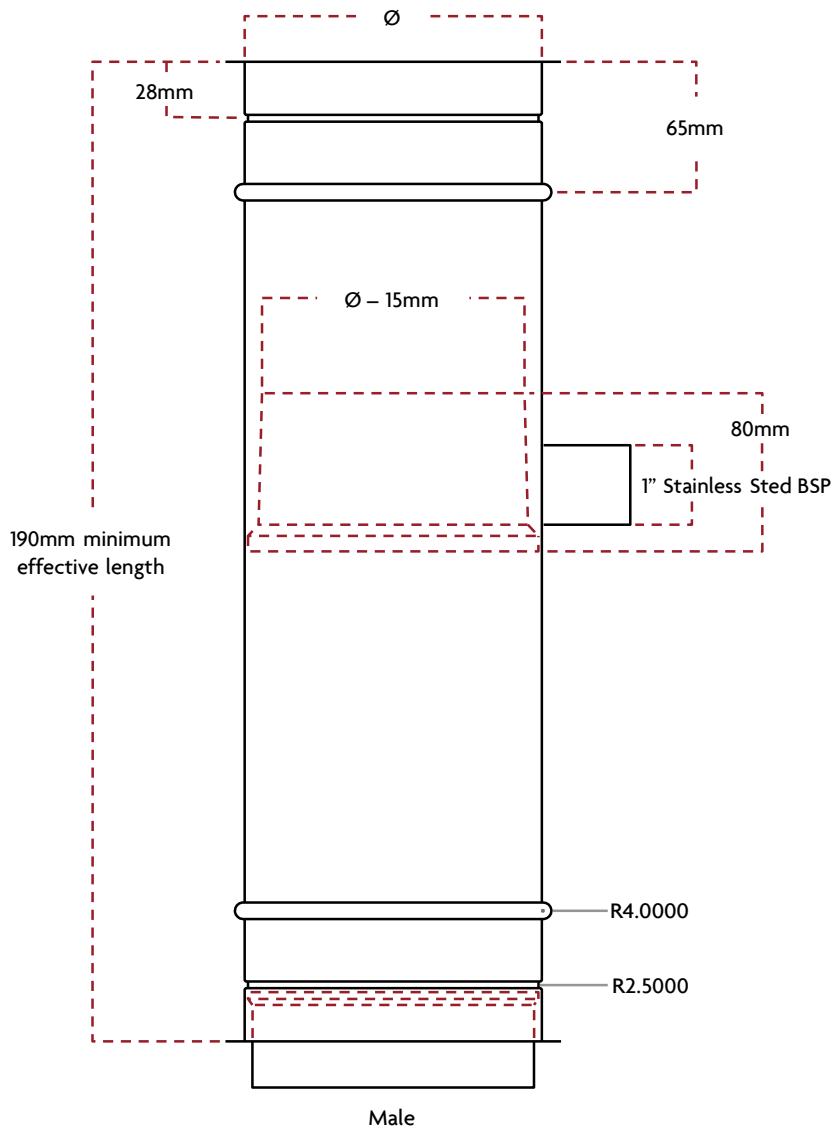
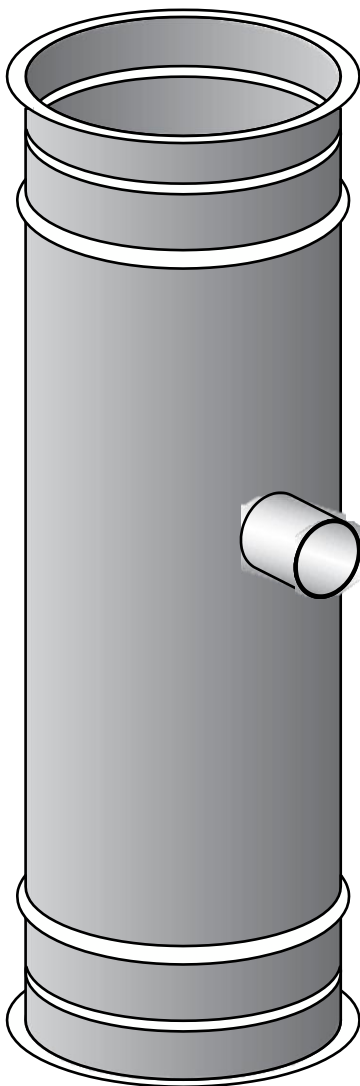

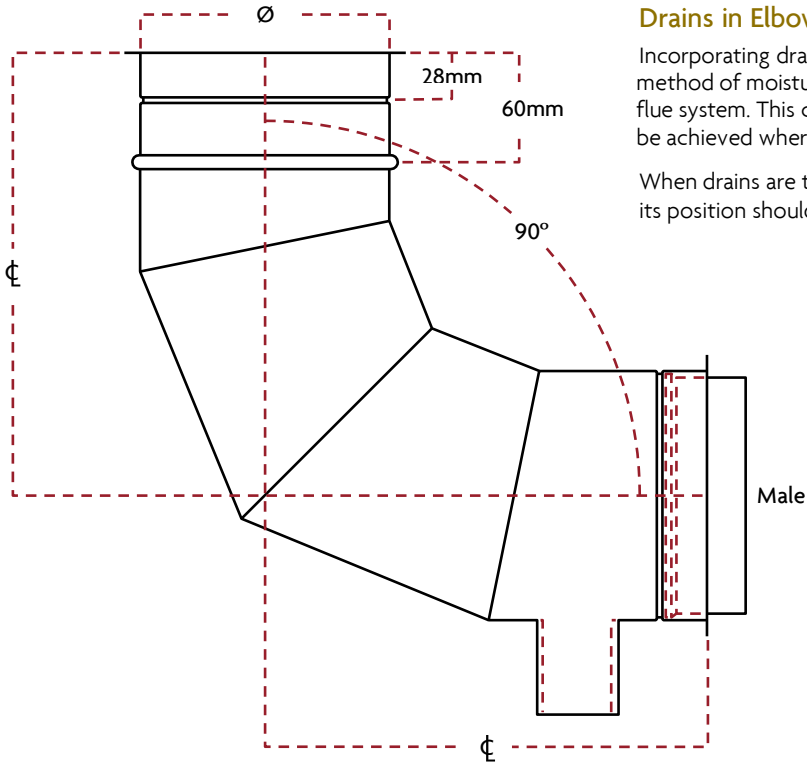

### Drains in Elbows

Incorporating drains with Elbows can also be an effective method of moisture (condensate) removal from within a flue system. This component allows for drain positions to be achieved where space is at a minimum.

When drains are to be fitted within a male end of an Elbow its position should be established using the method shown.

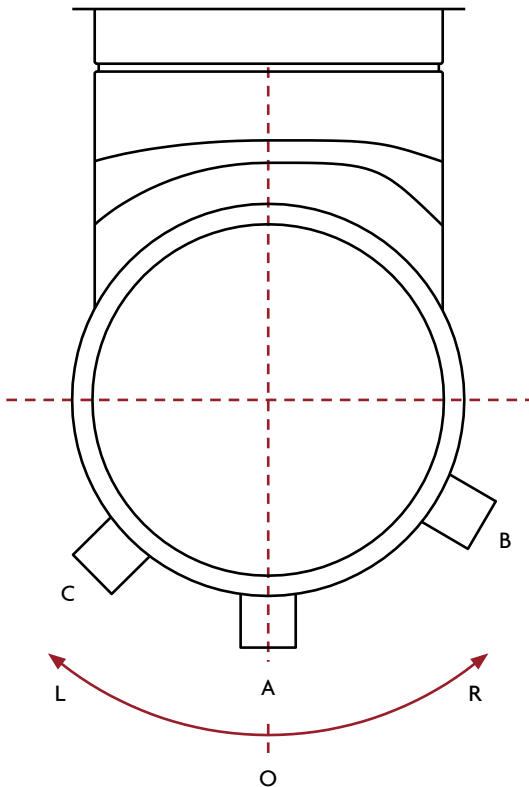

### Elbows viewed on male end

Drain for an upright Elbow (drain "A") will be designated O.

Other drains will be designated either L (left) or R (right) and the angle from position O. i.e Drain "B" will be R60 and "C" will be L45.

# Single-Skin Deltavent

## Clean Out Door (C.O.D)

This component is used to close off the unused openings within the flue system. These caps can be installed either horizontally or vertically and are secured with a flanged V-Band joint which is easily removed to enable access for cleaning and inspections.

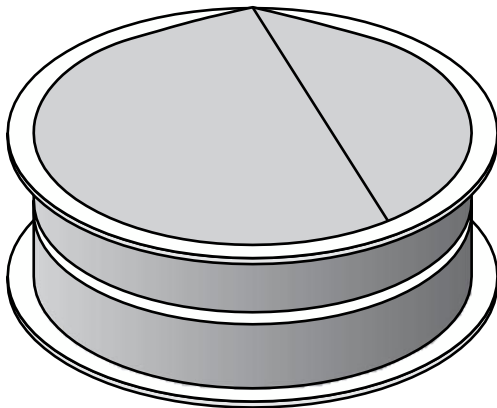

Female

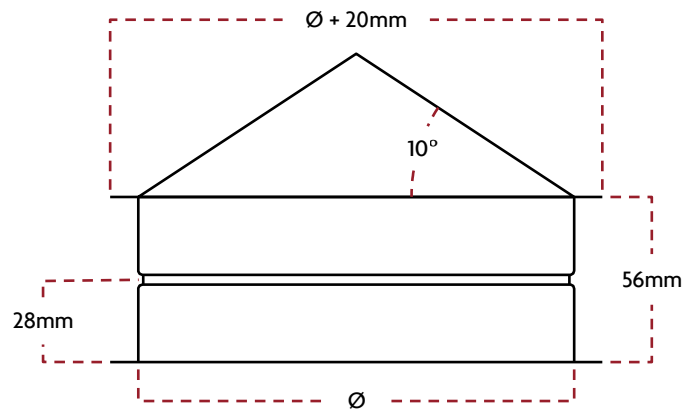

The ability to manufacture Clean Out Doors complete with a 1" Stainless Steel threaded B.S.P socket is also available on request. These caps are positioned to close off the unused opening on the underside of the Base Tee, permitting pipe work to be attached for the removal of any condensate (moisture) build-up.

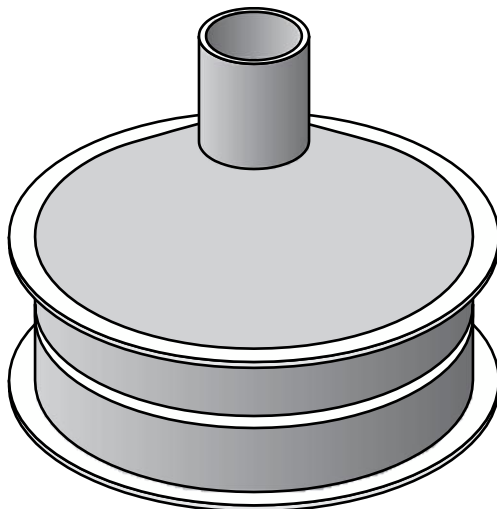

Female

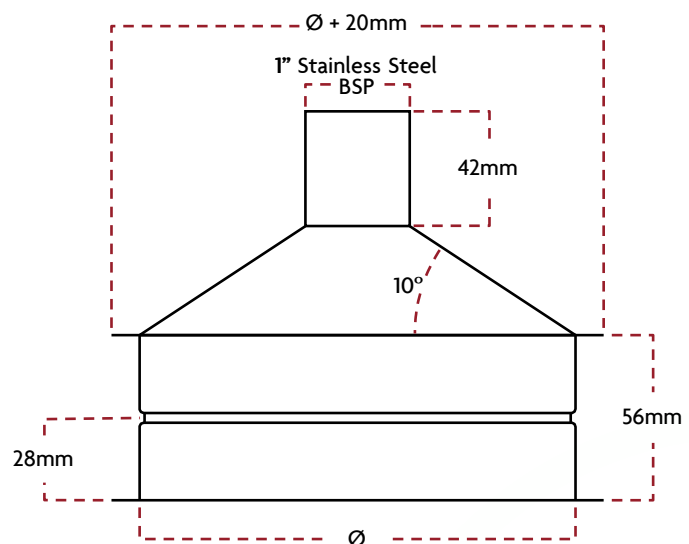

### NOTE:

All dimensions provided above are for the standard minimum. Non-standard C.O.Ds consisting with dimensions greater than those given can also be accommodated to your requirements.

### Reducers and Increaseers

A reducer/increaser is the most effective and efficient method of diameter change within a flue system.

This special item from the Single-Skin Deltavent range allows for the steady transition of flue gases to limit resistance and is available to order in all diameters and at custom lengths above or including those given.

Reducers and Increaseers are processed and manufactured using the same method so the location of it's male or female profile determines the application of use.

A1 Flue Systems acknowledge that there may be certain times where space is restricted. Therefore, the possibilities of developing unique items such as; offsets, reduced offsets or even increased offsets is often achievable. However, the degree of offset may result in the lengthening of reducer or increaser. (refer to illustration)

**NOTE: All dimensions given are the standard minimum.**

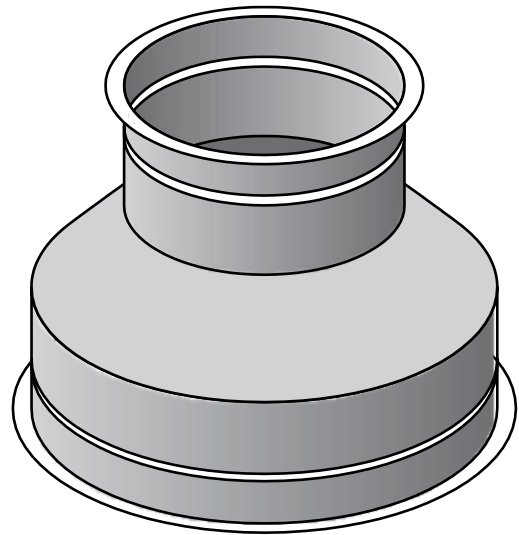
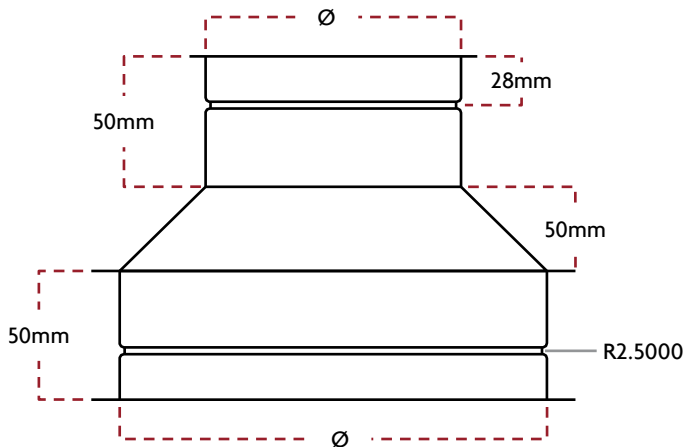
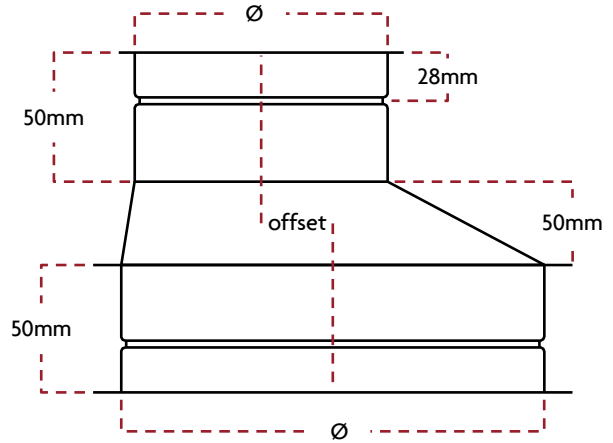

# Single-Skin Deltavent

## Appliance Adapters

Two types of Appliance Adapters are available for this product, both of which are designed to facilitate (assist) the connection of the vertically or horizontally positioned Single-Skin Deltavent to an appliance outlet.

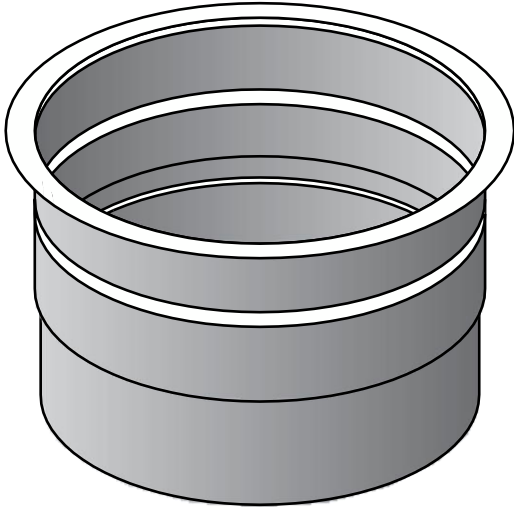

## 2-Piece Inner

Use where boiler female connections within +/- 10mm of flue liner  $\varnothing$ .

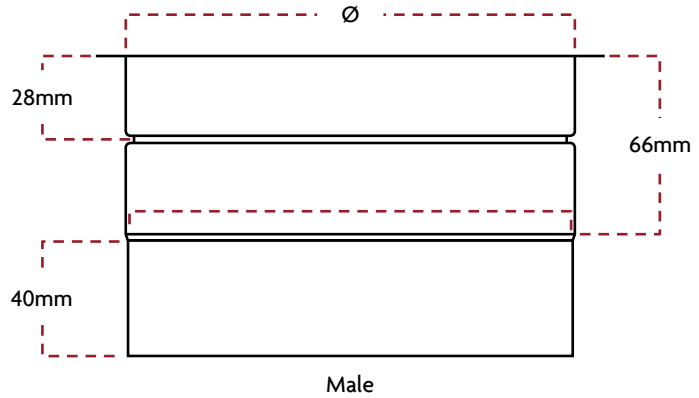

## 3-Piece Inner

Use where boiler female connection exceeds +/- 10mm of flue liner  $\varnothing$ .

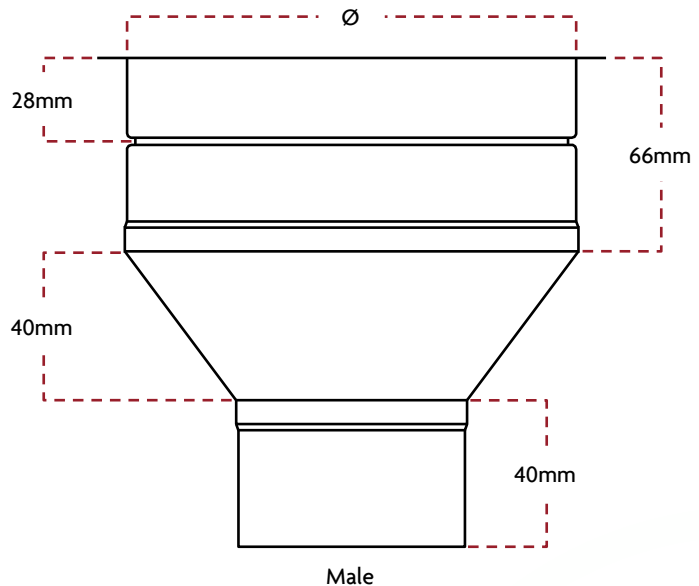
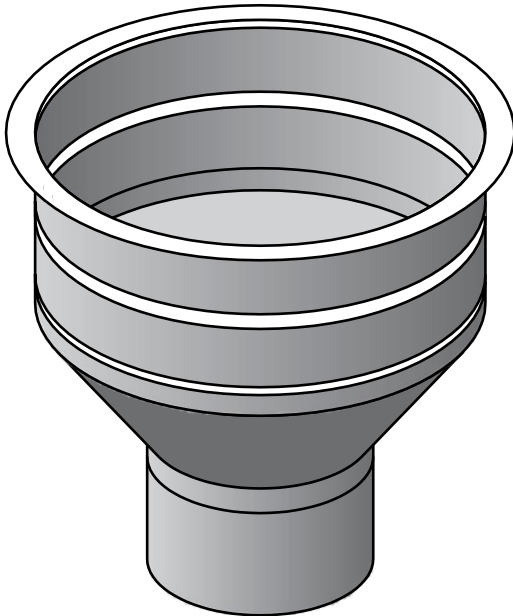

Manufacturing capabilities allow for the male connection spigot on either design to be supplied in all regular and irregular diameters and at increased lengths above those given.

## NOTE:

- All dimensions provided are standard minimum
- All Appliance Adapters consisting of diameters under 150mm are to be manufactured using, 0.7/0.6mm Grade 304 or 316 Stainless Steel.

### Fire Stop Kits

Designed to be applied where the Deltavent Single-skin chimney system requires a compartmental fire rating for both horizontal and vertical structure penetrations of up to four hours.

ø A	100	125	150	175	200	225	250	300	350	400	450	500	550	600	650	700	750	800	850	900	950	1000	1050	1100	1150	1200
B	150		200	225	250	275	300	350	400	450	500	550	600	650	700	750	800	850	900	950	1000	1050	1100	1150	1200	1250
C	300		400	425	450	475	500	550	600	650	700	750	800	850	900	950	1000	1050	1100	1150	1200	1250	1300	1350	1400	1450
D	154		204	229	254	279	304	354	404	454	504	554	604	654	704	754	804	854	904	954	1004	1054	1104	1154	1204	1254
E	127		177	197	222	247	272	322	372	422	472	522	572	622	672	722	772	822	872	922	972	1022	1072	1122	1172	1222

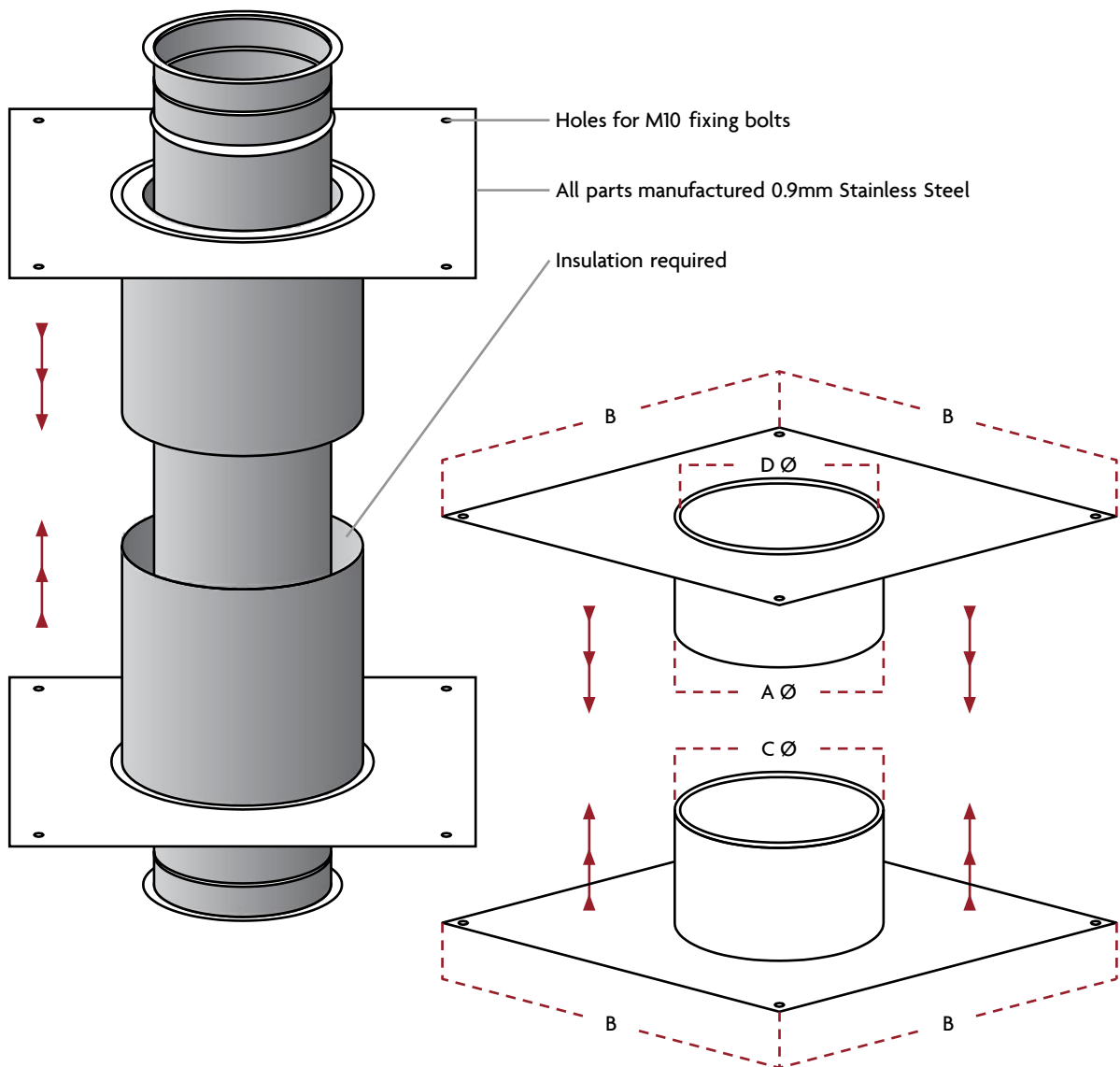

# Single-Skin Deltavent

## Draught Stabiliser

Draught Stabilisers are used for the control of draught within a Single-Skin Deltavent chimney system caused by the effect of lighter flue gases rising within the chimney stack.

The effectiveness of the Draught Stabiliser is established using a swinging vertical gate pivoted slightly above centre, such that under static conditions the gate will hang vertically down. This gate can be weighted accordingly so that it is lighter or heavier to move, and in doing so varies the draught (suction) level.

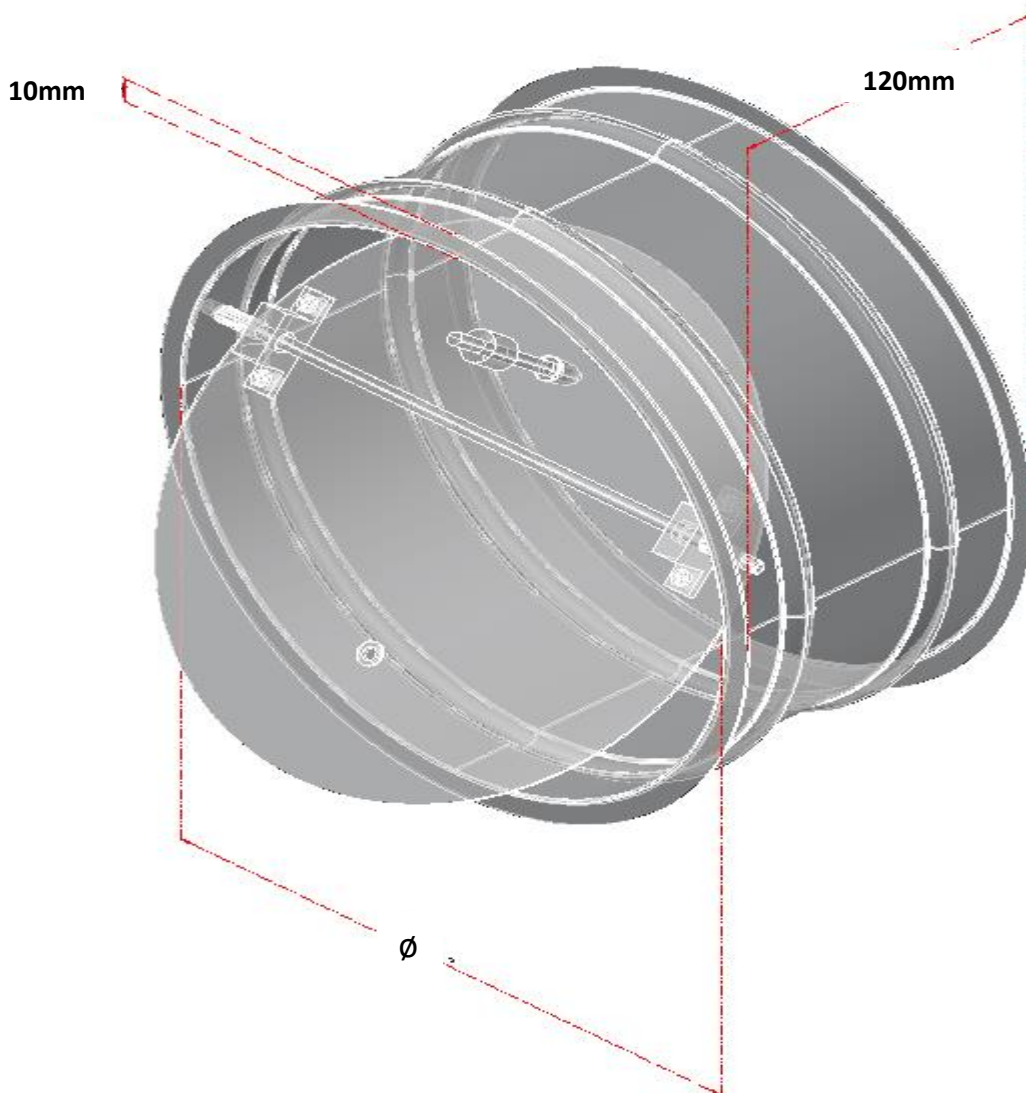

This component is manufactured (as standard) to the values provided using either 0.9mm Grade 304 or 0.9mm Grade 316 and is secured into position with a V-Band. This enables frequent easy access for both cleaning and inspections.

**NOTE :** There are certain locations where these devices are best situated, for example; within a vertical part of the boiler connection for effect on the individual appliance, at the end of a combined header or below the Base Tee of the riser for overall effect.

### Terminations

Three types of terminations are available for the Single-Skin Deltavent product, all of which have been designed to allow/aid the safe release of flue gases whilst giving a decorative end finish.

Single-Skin Deltavent terminals comprise of male locating spigots conjoined within a 10mm connection flange. All are fixed/secured to the top section of a vertical rise using both V-Bands provided.

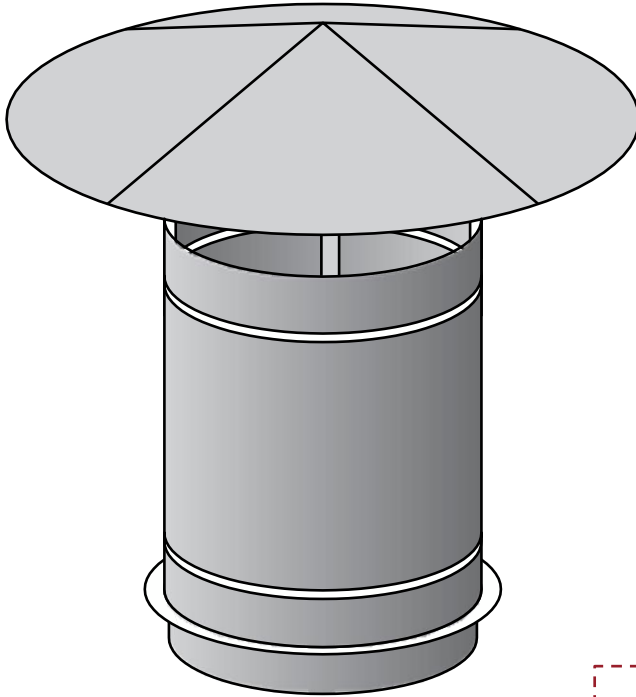

#### Rain caps

Designed for multiple appliances as well as providing a less restrictive all weather protected vent into the atmosphere.

#### Double-Inverted Rain caps

For the use on induced draught systems to prevent back pressure within the flue.

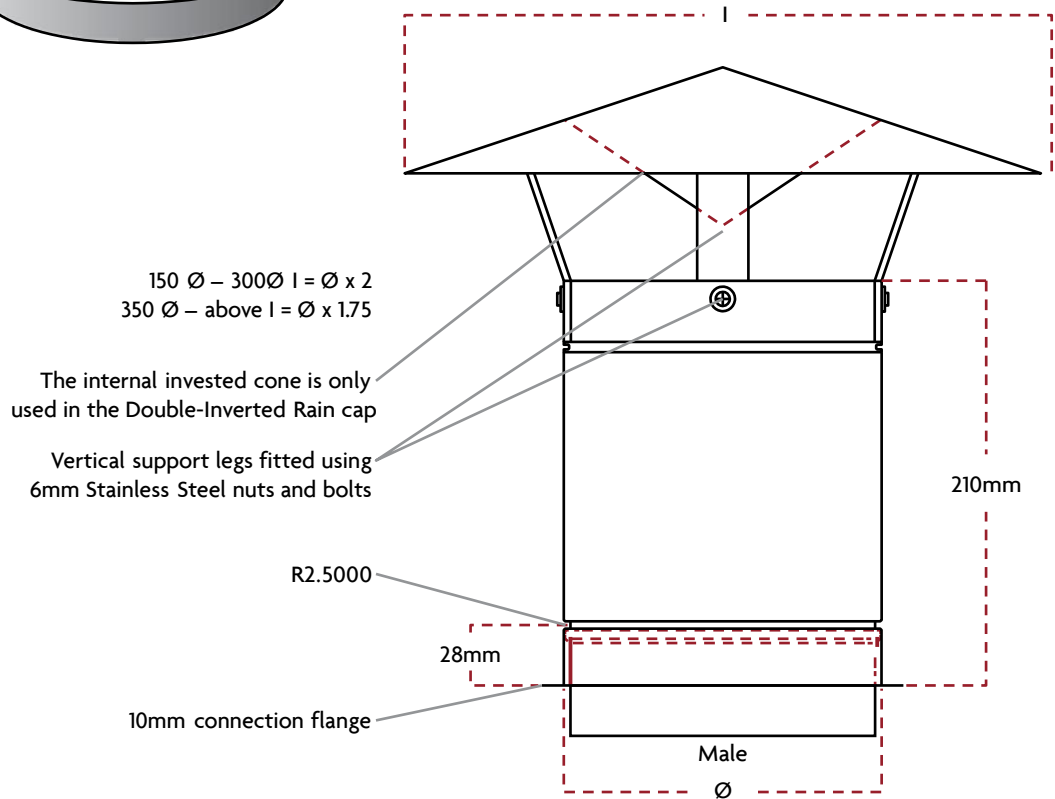



# Single-Skin Deltavent

## Single-Skin Deltavent Mesh Top

Mesh Tops allow for the unrestricted rapid release of flue gases into the atmosphere.

The effectiveness of the Single-Skin Deltavent terminal is established by its outlet diameter (free surface area). This outlet can be manufactured and supplied with or without Stainless Steel mesh and at a reduced diameter which will increase velocity of its existing gases.

Due to the nature of this open outlet design it is strongly recommended that the Single-Skin Deltavent Mesh Top should always work in conjunction with either a moisture (condensate) release point at the base of a vertical rise, or with a vertical Drainage Length fitted with an Internal Drain Trap.

**NOTE:** All dimensions provided above are for (standard minimum). Non-standard Mesh Tops consisting with dimensions greater than those given can also be accommodated to your requirements.

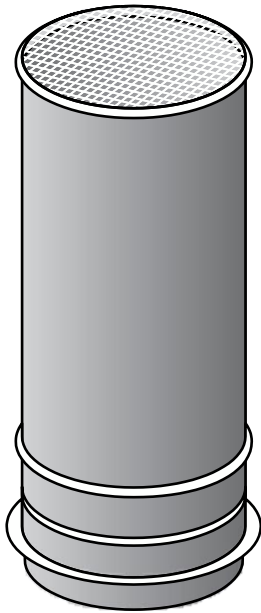

Male

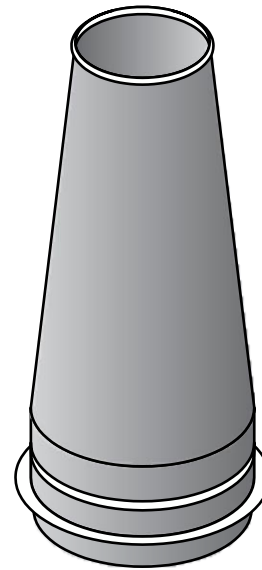

Male

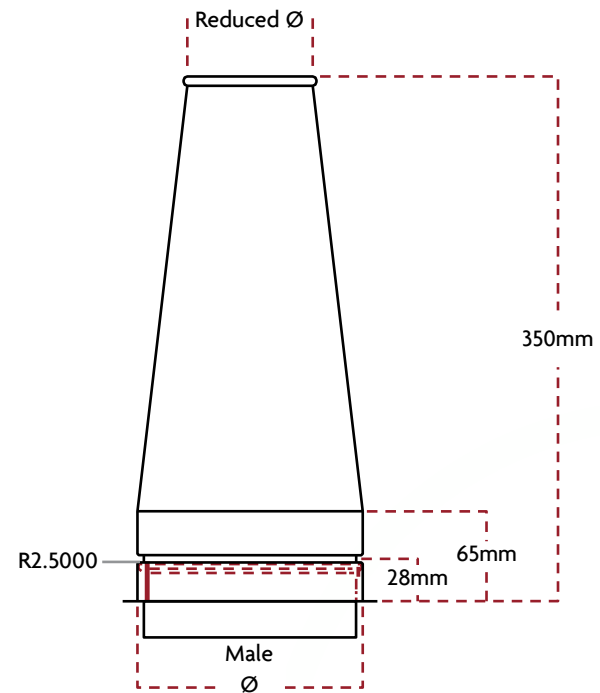
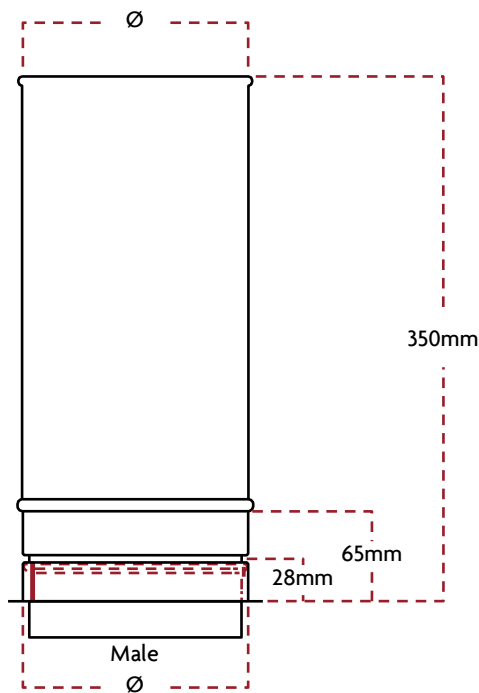

### Storm Collars

Storm Collars are obtainable in two well established designs which are to be used to apply an all-weather impermeable seal around a Single-Skin Deltavent vertical rise immediately after the exit through a Flashing.

Once the positioning has been achieved (directly above a flashing), the angled profile of the Storm Collar will divert and deny any access between the chimney flue case and Flashing upstand to all adverse weather.

All dimensions provided below are a (standard minimum). However, non-standard dimensions and diameters can also be accommodated if required.

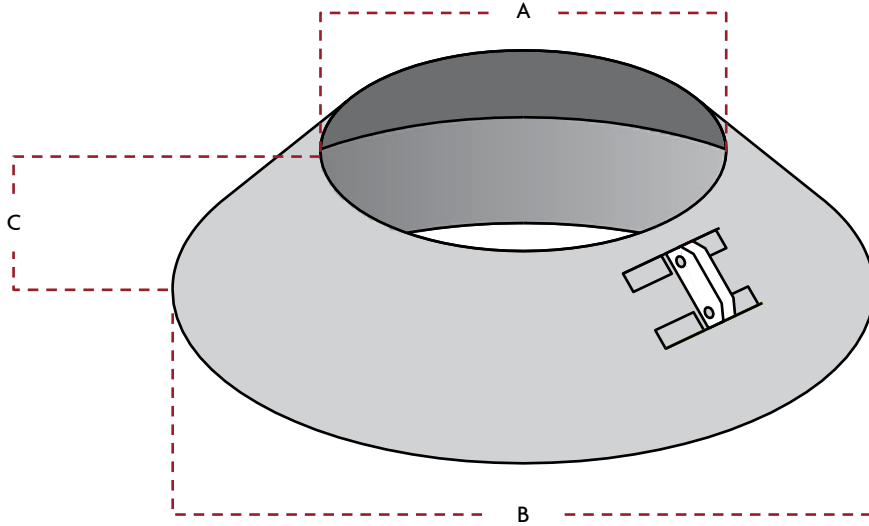

∅	100	125	150	175	200	225	250	300	350	400	450	500	550	600	650	700	750	800	850	900	950	1000	1050	1100	1150	1200
A	100		150	175	200	225	250	300	350	400	450	500	550	600	650	700	750	800	850	900	950	1000	1050	1100	1150	1200
B	250		300	350	375	400	425	450	500	550	600	650	700	750	800	850	900	950	1000	1050	1100	1150	1200	1250	1300	1350
C	80						100						150													

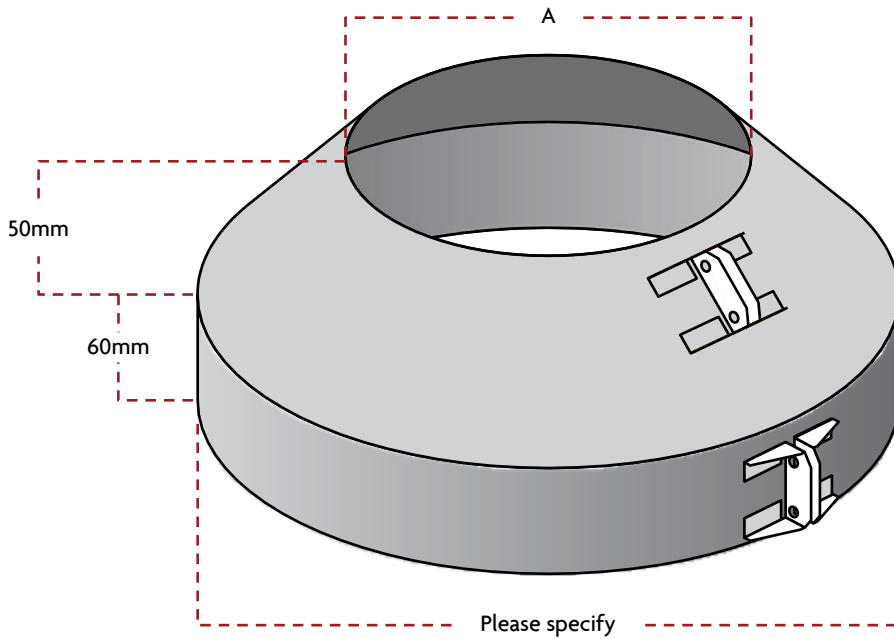

# Single-Skin Deltavent

## Flashings

Flashings are to be used as an effective method of providing weather protection to all building structures immediately after roof or chimney penetration of a vertically rising Single-Skin Deltavent chimney.

Two types of Flashings are obtainable for this system, both of which can be fabricated and supplied to suit all roof angles and chimney flue diameters including the irregular.

## Flat Flashings

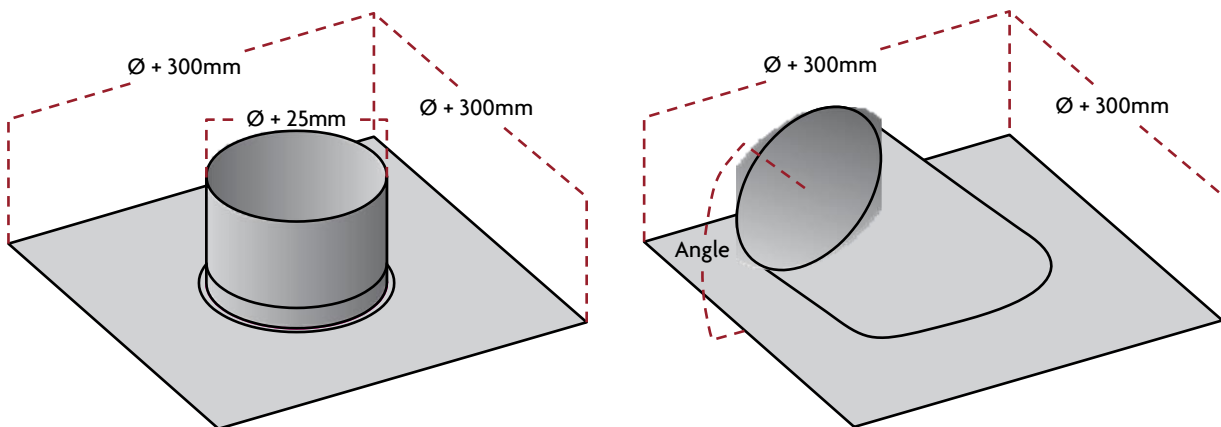

## Box Flashings

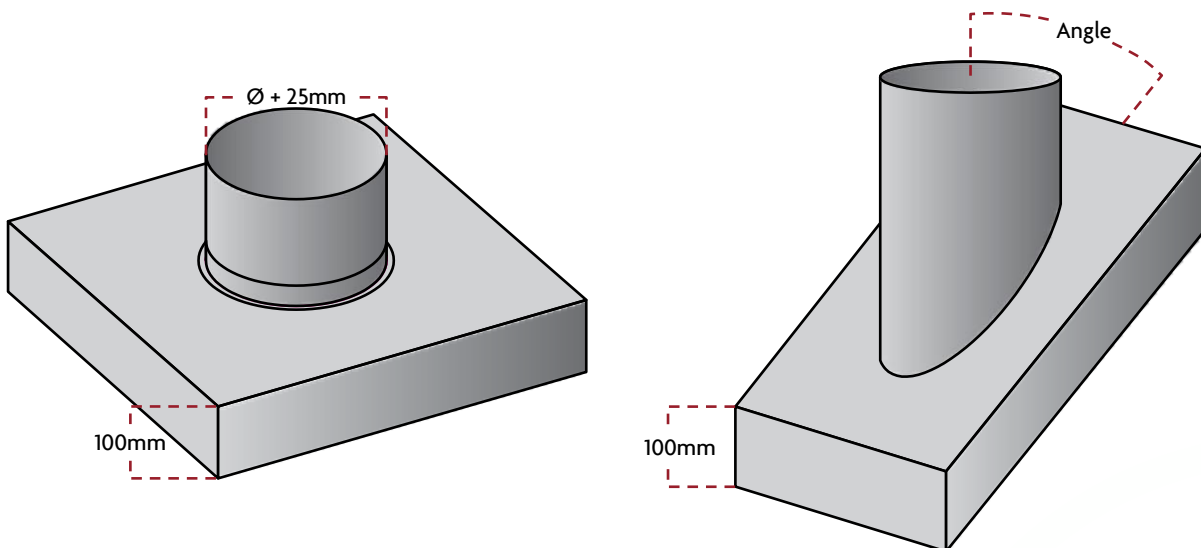

NOTE: Picture illustrations and values provided are for standard items. However, unique Flashings combined with multiple upstands and increased values can also be accommodated if required.

### Support Components

The complete range of support components listed below have been successfully designed and tested to accommodate the chimney weight whilst providing flexibility and ease on installation as well as stability after installation.

#### Thrust Support Plate

Thrust Support Plates provide load bearing lateral support for the vertically adjoined Single-Skin Deltavent. This component is suitable for supporting on both Uni-Strut or Cantilever brackets and can be constructed in either 3mm Stainless Steel (for external applications) or 3mm Galvanized Steel (for internal applications).

**NOTE:** Picture illustrations and values provided are for standard items. However, unique Thrust Support Plates combined with multiple Thrust Collars and increased values can also be accommodated if required.

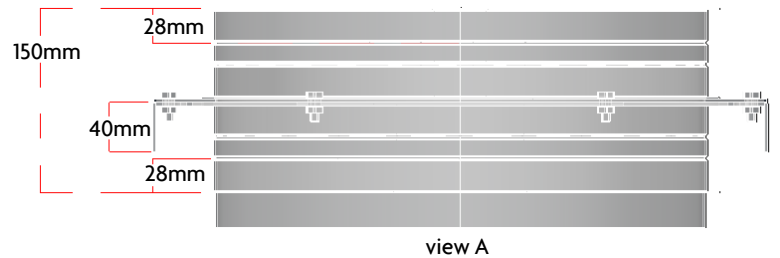
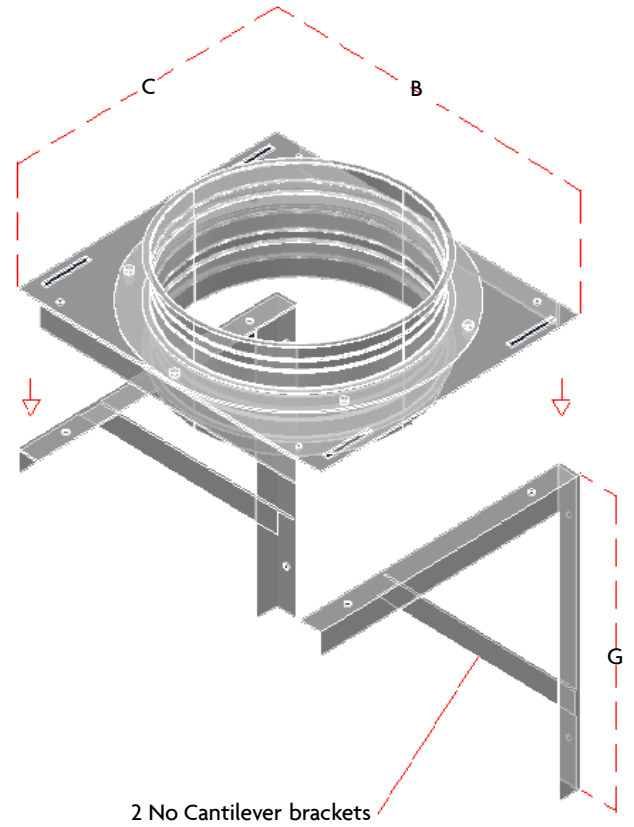
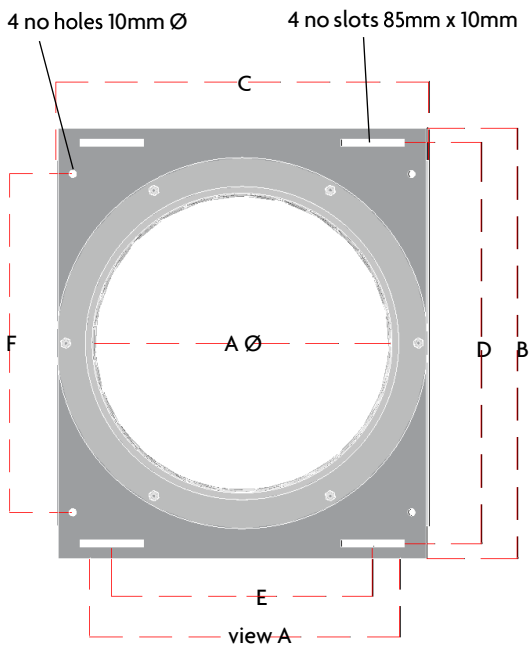

∅ A	100	125	150	175	200	225	250	300	350	400	450	500	550	600	650	700	750	800	850	900	950	1000
B	290		312	331	357	382	434	478	529	580	631	628	752	803	854	905	944	994	1044	1094	1144	1194
C	234		254	273	299	324	356	400	451	502	553	604	654	705	756	807	846	896	946	996	1046	1096
D	250		272	291	317	342	394	439	489	540	591	642	712	763	814	865	904	954	1004	1054	1104	1154
E	103		103	122	148	173	205	249	300	351	402	453	503	554	605	656	695	745	795	845	895	945
F	188		208	227	253	278	310	354	405	456	507	558	608	659	710	761	795	850	900	950	1000	1050
G	200		254	273	299	324	356	400	451	502	553	604	654	705	756	807	848	896	946	996	1046	1096



### Universal Rings

Universal Rings are to be used to achieve the lateral stability and accurate alignment of a Single-Skin Deltavent chimney system.

This component is available with or without swivel lugs incorporated and is suitable for supporting horizontal or inclined runs off 10mm Drop Rod at intervals not exceeding 3 metres.

Universal Rings are manufactured using Stainless Steel and to the values provided below. However, non-standard unique items can also be accommodated if required.

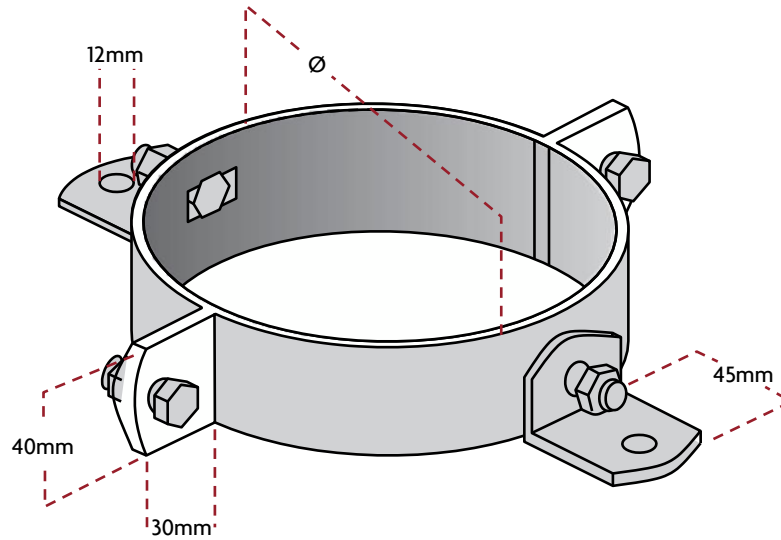



#### Head office

Maun Way, Boughton Industrial Estate, New Ollerton,  
Nr. Newark, Nottinghamshire, NG22 9ZD

Tel: +44 (0)1623 860 578 Fax: +44 (0)1623 835 548  
info@a1flues.co.uk www.a1flues.co.uk

#### Sales

Tel: +44 (0)1623 867 304 Fax: +44 (0)1623 835 548  
sales@a1flues.co.uk

#### Technical

Tel: +44 (0)1623 867 303 Fax: +44 (0)1623 835 548  
technical@a1flues.co.uk

#### FuranFlex® enquiries and sales

Tel: +44 (0)1623 860 578  
furanflex@a1flues.co.uk

**EXCELLENCE • PRIDE  
PASSION • PRECISION**

---

